

EasyKit®

ACDxV40EX

Sales Floor To Stock Room Battery Powered Access Controlled Door

Designed to limit stockroom access to employees only, the ACDxV40EXx1S-1 EasyKit offers industry-proven code compliant life safety and security hardware for high-use doors with a cost-effective alarmed access control solution. Employees enter a common access code, temporarily bypassing the alarm and allowing an employee to enter the stockroom without sounding the alarm. A stockroom keypad is no longer required and the employee can quickly and easily return to the sales floor without fear of an alarm sounding. Customers trying to enter the stockroom will cause an alarm to sound, which can only be reset with an employee entering a common access code. Code compliant for both emergency exit doors and fire exit doors, the stockroom to sales floor EasyKit helps control who enters your stockroom.



Benefits

- Cost-effective alarmed access control with panic hardware in one easy-to-install kit
- Pin code can be changed in seconds with no keys or cards to manage
- Easy-to-replace standard 9-Volt batteries
- Tough and durable design for years of trouble-free service in high-use environments
- Minimal door prep with no through-door wiring saves time and money

Features

- Alarm features digital codes for Master, Management and Passage (used for Auto-Arming)
- Non-handed
- Heavy-duty angled end cap deflects damage away from panic device
- Stainless steel deadlocking Pullman-type latch bolt on exit device
- Field sizeable panic device
- Alarm is tamper switch supervised
- Alarm has audible low battery warning
- Multiple door monitoring
- Alarm can be hardwired (power transfer or electric hinge required and sold separately)
- Alarm has audible volume control adjust

Mechanical Options

- F - 3-Hour Fire Rated (panic device) - Specify ACDxFV40EXx1S-1
- 36 - Fits 36" door width for right hand reverse door (Std.) - Contact factory for left hand reverse
- 48 - Fits 48" door width for right hand reverse door - Specify ACDxV40EXx1S-2 - Contact factory for left hand reverse

Accessories (sold separately)

- SN1 - Sex Nut Fasteners
- SSK1 - Torx Security Screw Kit
- EWH8-626 - Electric Hinge
- PT-5 - Power Transfer

For more information on V40 Series exit devices, see individual catalog pages

Technical Information

- Door Types - Wood, Hollow Metal, Fiberglass or Aluminum
- Door Stile - Fits minimum 5" wide stile with 99 strike (Std.)
- Alarm dimensions: 9.5"L x 2.5"W x 2.66" D
- Door Thickness - Fits standard 1-3/4" - 2-1/4" (for other door thicknesses, contact factory)
- Machine and Sheet Metal Screws (Std.)
- Alarm features 95dB (10') Piezo electronic sounder
- Rail - Heavy Ribbed Aluminum Extrusion

Finishes

Value Series Finish: 628 Aluminum (Std.)
 Alarm Finish: Metallic Silver

Riser Diagram

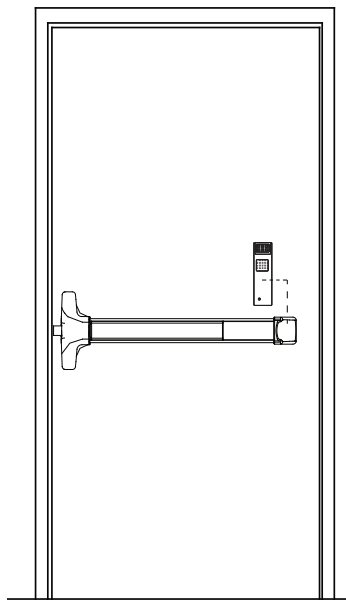

Keypad alarm mounted on door

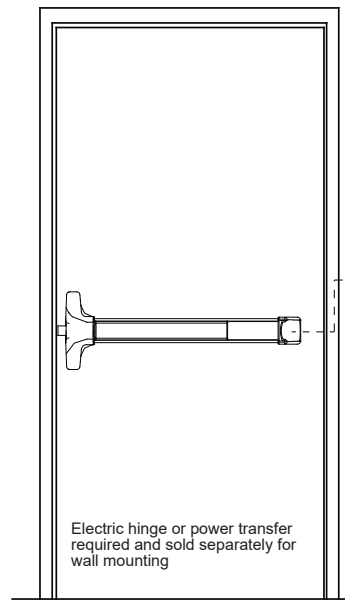

Keypad alarm mounted on wall

Dimensions

Value Series

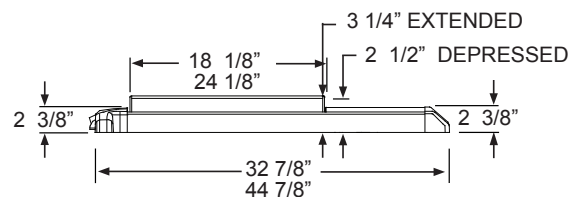

Door Alarm

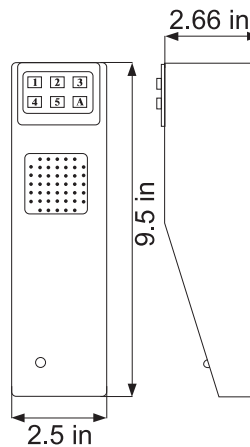

Detex Limited Warranty

10 Year Mechanical / 2 Year Electrical Manufacturer's Limited Warranty

Where Trust is Built™
DETEx[®]
Life Safety and Security Door Hardware

Detex Corporation
 302 Detex Drive
 New Braunfels, Texas 78130-3045 USA
 PH. (830) 629-2900
 (800) 729-3839
 FAX (800) 653-3839
<http://www.detex.com>
 USA Sales:
marketing@detex.com
 International Sales:
export@detex.com

 Cancer & Reproductive Harm - www.detex.com/prop65