



Detex Corporation, 302 Detex Drive, New Braunfels, Texas 78130-3045
830-629-2900 / 800-729-3839 / Fax 800-653-3839 / Text photos only: 830-481-6433 / INTERNET: www.detex.com

INSTALLATION INSTRUCTIONS FOR PS80xLT POWER SUPPLY

dwg# 106000

FOR INDOOR USE ONLY
TO BE MOUNTED IN A PROTECTED AREA

Table of Contents	Page
Device parts breakdown view.....	2
Part number list.....	3
Installing the enclosure.....	4
Connection diagram	5
Connection instructions.....	6
Connection instructions continued.....	7

FILTERED AND REGULATED POWER SUPPLY
 INPUT: 24VAC @ 3 amps 50/60 Hz
 OUTPUT: 24VDC @ 2 amps / 12VDC @ 500mA
 Evaluated for UL Operation with Detex® TMFR277 only
 OPTIONS:
BB - Battery Backup

CAUTION: De-energize unit before servicing.

ATTENTION : éteindre l'unité avant l'entretien.

Enclosure provides protection against electric shock and fire. Do not open without removing power.

Only trained personnel should operate or service this equipment.

Le couvercle protège contre les chocs électriques et incendies. Ne pas l'ouvrir sans préalablement couper l'alimentation. Seul le personnel formé doit opérer ou effectuer

l'entretien de cet équipement.

For WARRANTY information,
scan code below or
go to www.detex.com/warranty



For device installation videos,
scan code below or
go to www.detex.com/videos



Owner's Copy

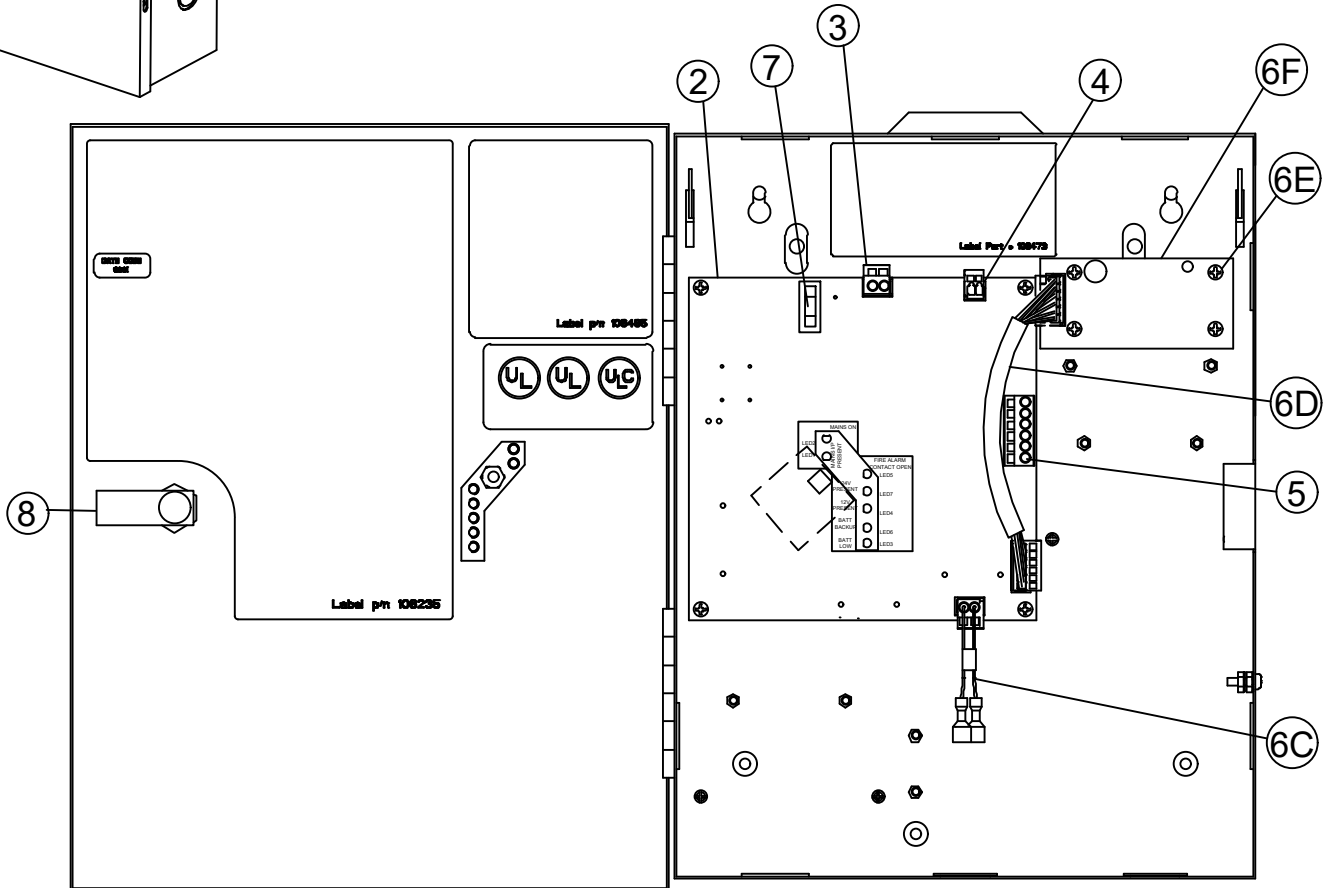
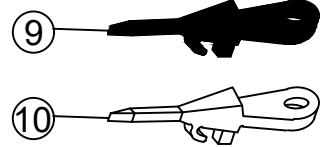
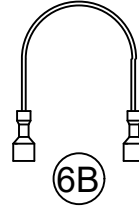
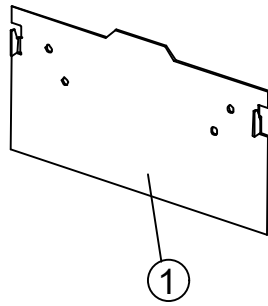
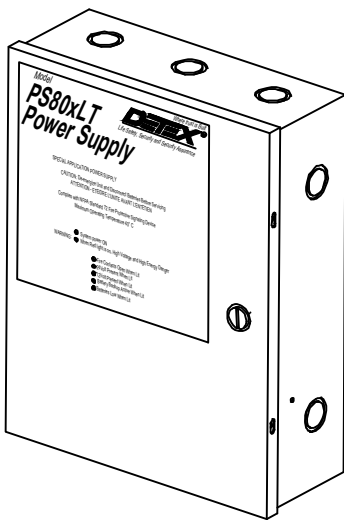

(for clarity, some components not shown)

PARTS BREAKDOWN		
Item	Order Part #	Description
1	106003	Mounting Plate PS80
2	106014	PWA, Main Board, LT
3	106206-2	Terminal Block, 2 position, LT
4	106208-2	Terminal Block, 2 position
5	106206-6	Terminal Block, 6 position
6KIT	106475	Battery & PWA Kit (optional - includes 6A-6F)
6A	BB-0001/0/12	Battery, 12V, 4.5A (2 required, not shown)
6B	102979	Assembly, Battery Connector
6C	106476	Cable, Battery, PS80 Power Supply
6D	106017	Interconnect Battery Cable
6E	PP-5367-106	Screw, Mach, 6-32 x 3/8 PPH
6F	106008	PWA, Battery Charger Interface
7	104267-3	Main Fuse, 2.5A Slow Blow
8	106029	Kit, Lock Cam and Key, PS80 (optional, plastic lock is standard)
9	106472	Tool, Wago, Red, 5.08mm (for orange connectors)
10	106472-1	Tool, Wago, White, 3.50mm (for white connectors)

Installing the Enclosure For Indoor Use only. To be mounted in a protected area.

Tools required: Safety glasses, Pencil, Level, Drill, Drill bit set, #4 Phillips screwdriver, Medium Flat screwdriver

See Fig 1:

1. #10 x 1" sheetmetal screws (p/n PP-5183-68) are included with the enclosure for mounting the plate and enclosure to the wall. Other mounting hardware such as concrete anchors or expanding anchors may be required for different types of mounting surfaces.
2. Install mounting plate level in desired location.

Fig. 1

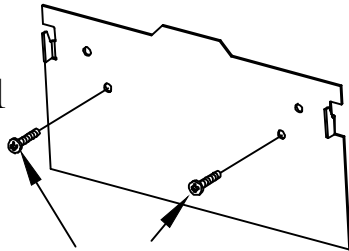

mounting plate attachment holes and screws (two) (see notes 1 & 2)

See Fig 2:

3. Slide the enclosure over the mounting hooks & mark the four holes at the locations shown inside the enclosure in Fig 3. Remove the enclosure from the hooks to drill the 4 mounting holes.
4. Secure the enclosure to the wall at these four locations from inside the enclosure.

Fig. 2

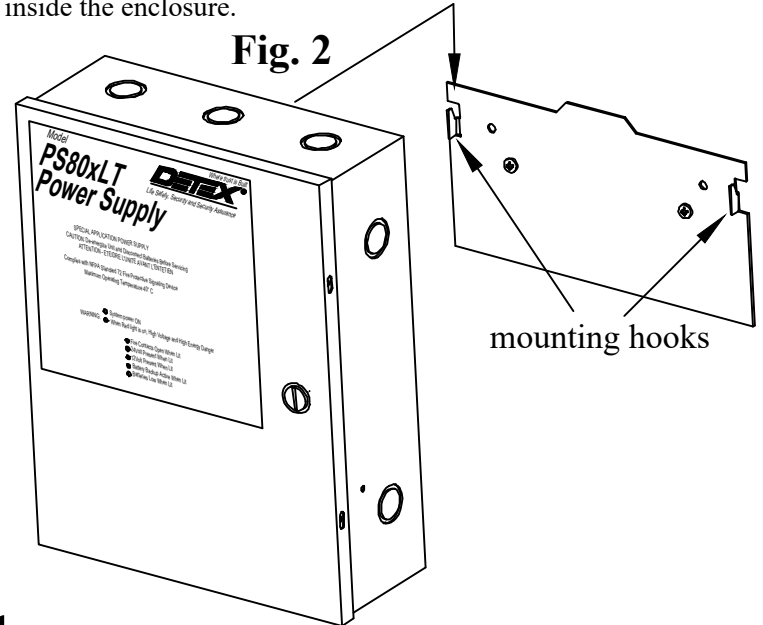
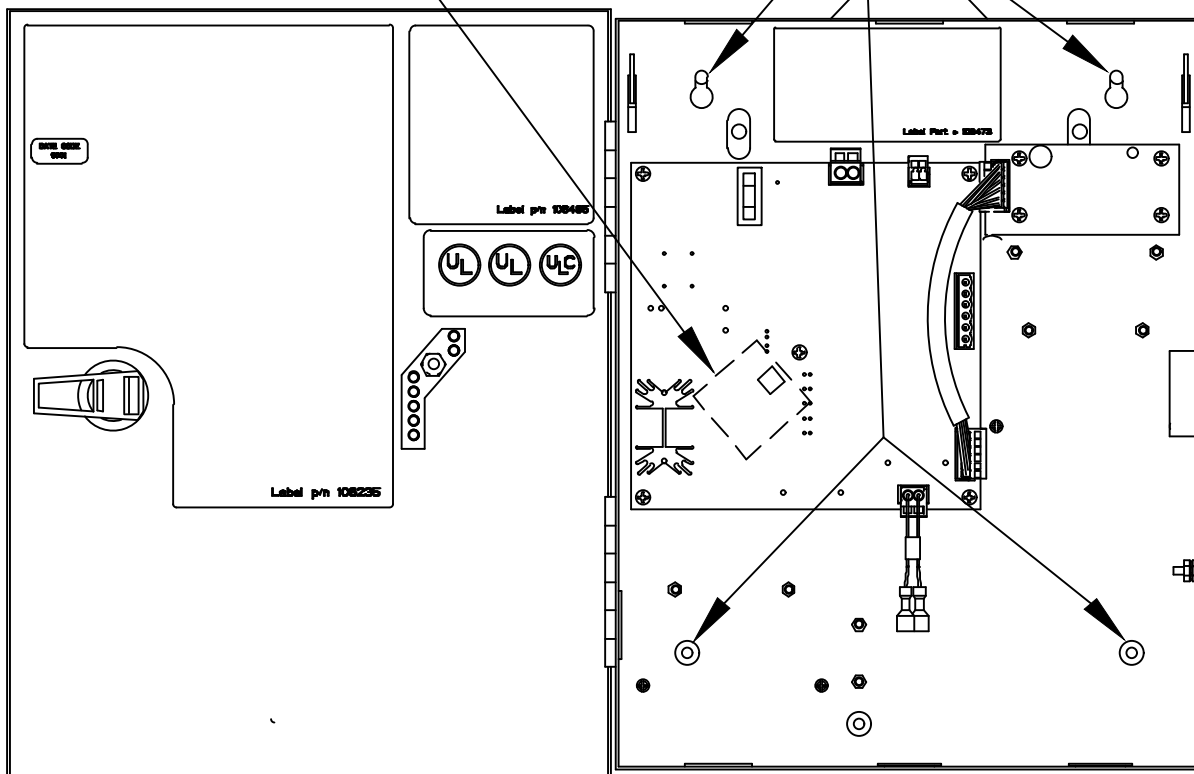

Fig. 3 Mounting holes

remove foam shipping block



(for clarity, some components not shown)

Connection Diagram and Instructions

The PS80xLT is a regulated and filtered power supply. It has a primary output voltage of 24 volts DC and a secondary output of 12 volts DC.

Refer to the drawing of the power supply (Figure 1A) for connections and features. All connections and adjustments should be made with the power supply de-energized **AND** main power switch (item 3) in the OFF position.

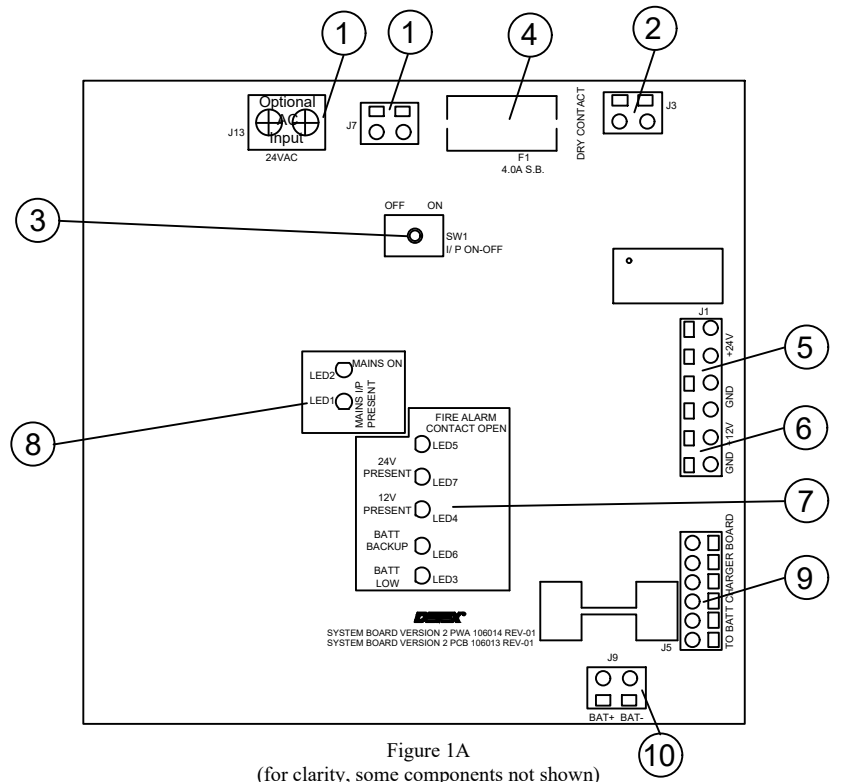
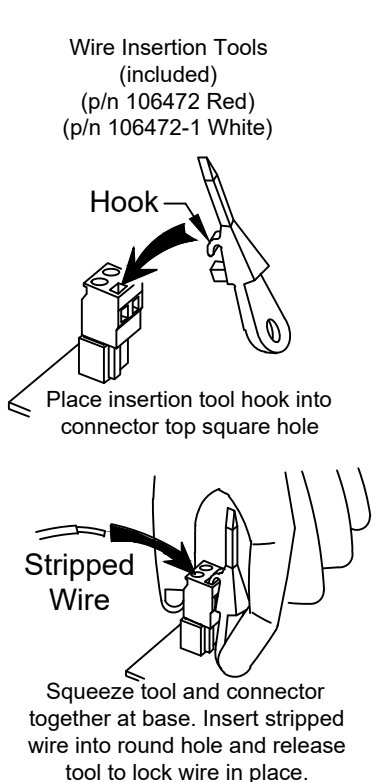

1: Main Power Connection (J7 and J13 optional).

Input power is 24 volts AC at 3.5 amps maximum current. This connection is not polarity sensitive. Leave circuit de-energized while installing and servicing unit. Disconnect batteries if present.

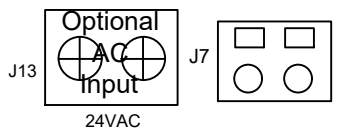

2: Fire Loop Control (J3).

The fire loop control requires a connection be made between the two terminals using a dry contact to enable the output voltages. Some locking devices require this terminal be connected to the building fire system. For independent operation, a jumper wire may be used to make the connection. When the connection is made, the power supply outputs 24 volts at J1, pins 3 through 6 (see item 5). LED 5 will turn off when the circuit connection is made (see item 7). If the circuit is open, the output relay is de-energized and the 24 volt output of the power supply is turned off, LED 5 will light indicating an open fire loop. 12 volts at pins 1 and 2, item 6 are always present.

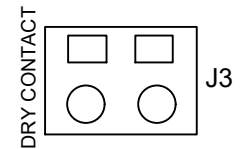

3: Main ON-OFF Switch (SW1).

This switch can be used to de-energize the power supply for service and adjustments. Voltage is still present inside the enclosure as long as the main power at J7 or J13 is still energized. Caution should be used when performing service even when this switch is used.

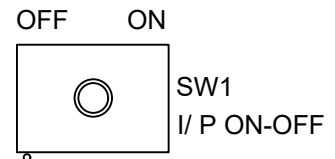

4: Main Power Fuse (F1).

This is a slow blow fuse and protects the main power into the power supply PWA. If the fuse fails, check and correct the cause of the overload before replacing with Littlefuse 0218004.HXP, Detex p/n 104267-4 or equivalent fuse.

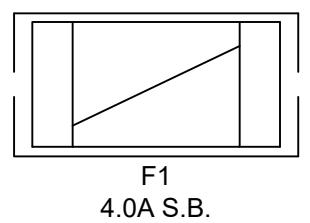

5: 24 volt output terminals (J1, pins 3-6).

The power supply outputs 24 volts at a maximum of 2 amps total current.
 The output is protected by a thermally resettable fuse.
 The output is DC, and the PWA is marked with polarity indicators.

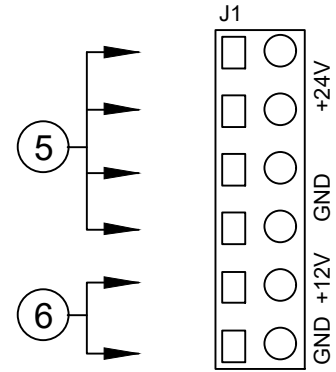

6: 12 volt output terminals (J1, pins 1-2).

The power supply outputs 12 volts at a maximum of 500 milliamps total current with or without fire loop.
 The output is DC, and the PWA is marked with polarity indicators.

7: System status LEDs.

These 5 LEDs indicate the status of key features of the power supply.
 LED 5 lights yellow when the fire loop input is open. System outputs are disabled.
 LED 7 lights blue when 24 volts DC is present at the output of the regulator.
 Output at J1 is disabled when the fire loop is open.
 LED 4 lights white when 12 volts DC is present at the regulator.
 LED 6 lights green when the optional battery charger board, batteries and cables are installed.
 LED 3 lights orange when the optional batteries are discharged. If they are over 3 years old, replacement may be needed.

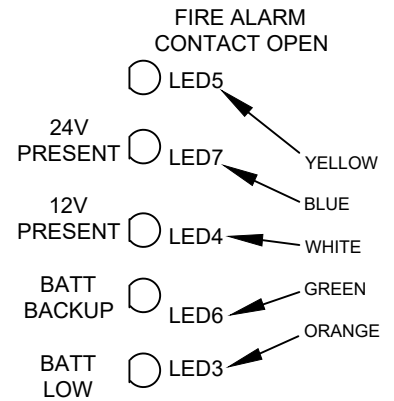

8: Input status LEDs.

LED 1 lights amber when input power is applied to the power supply.
 LED 2 lights red when the Main switch is turned ON (item 3).

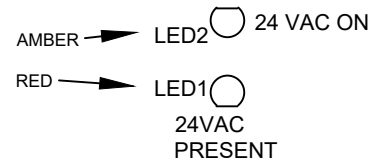

9: Optional battery charger connector (J5).

If ordered as a factory option, this connection will be already installed.
 If added in the field, use Detex p/n 106475 Battery and PWA kit and follow supplied instructions.

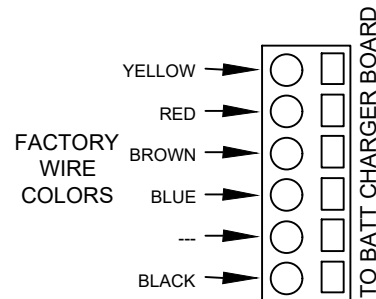

10: Optional back up batteries (J9).

These batteries come supplied when this option is factory ordered or can be ordered separately. The add on kit is Detex p/n 106475. Follow included instructions. Observe polarity when installing batteries.

