

Detex Corporation, 302 Detex Drive, New Braunfels, Texas 78130-3045
(830)629-2900 / 1-800-729-3839 / Fax (830)620-6711
E-MAIL: detex@detex.com INTERNET: www.detex.com

INSTALLATION INSTRUCTIONS FOR 08D x 2W, 09D x 2W and 14D x 2W TRIM

Drawing numbers:
105665 for 08D X 2W
105666 for 09D X 2W
105668 for 14D X 2W

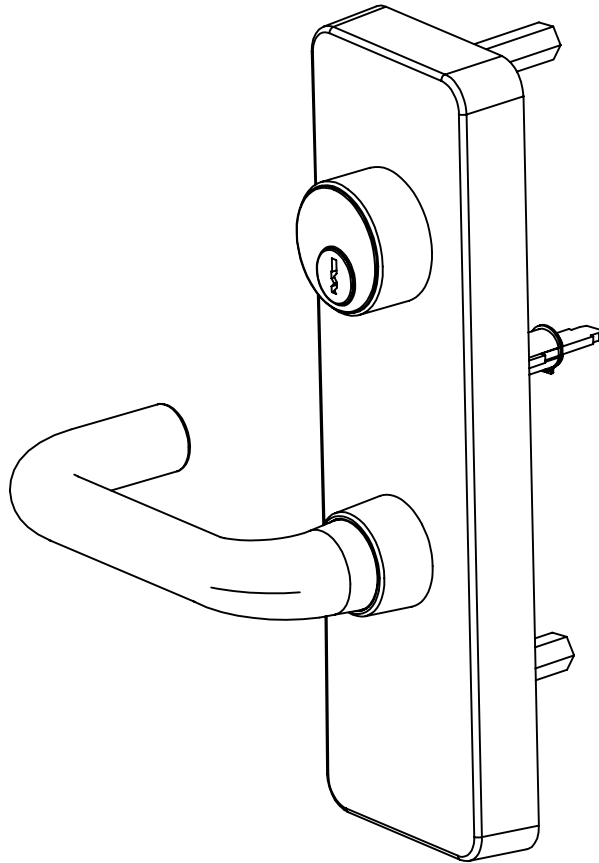

Owner's Copy

PREPARING THE TRIM:

1. The lever trim is handed. Refer to "CHANGE LEVER HANDING" on pages 4 & 5 if needed.

INSTALLING THE MORTISE CYLINDER 08D & 09D FUNCTIONS ONLY (14D does not require a cylinder):

2. A short cylinder collar is supplied for mortise cylinders. 1" to 1-1/8" long. For cylinders greater than 1-1/8", order tall cylinder collar p/n 100752-X.

3. Insert the mortise cylinder (not included). (See Fig below) Fasten the cylinder with the large hex nut.

Note: The key should turn the cylinder easily to slide the locking bar in both directions.

Caution: The back of the cylinder should not protrude beyond the depth of the trim escutcheon.

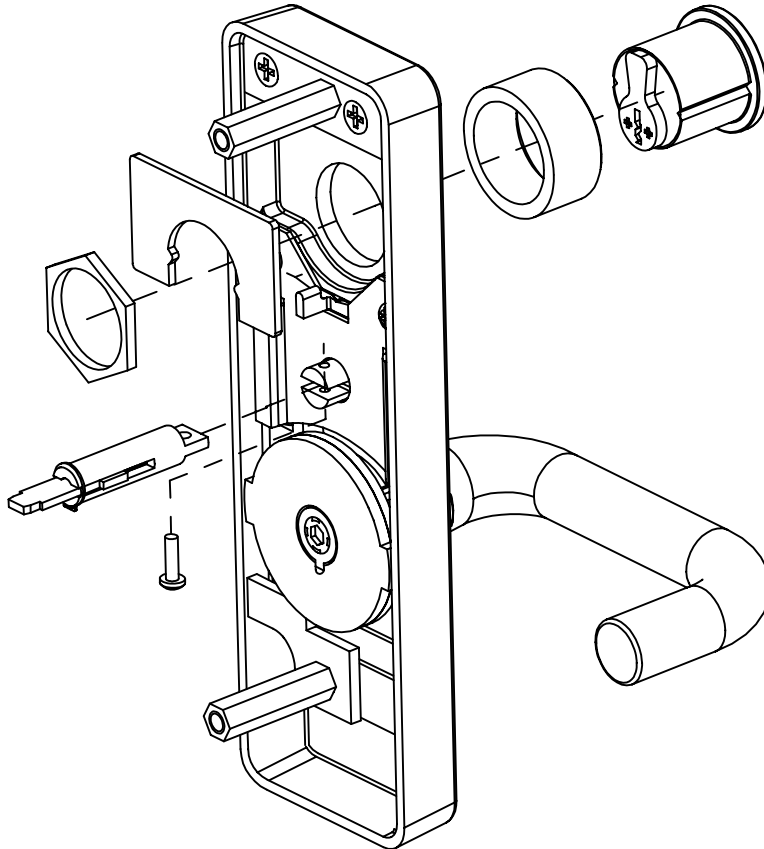

4. Attach the tailpiece extension to the top gear with screw provided.



PREPARING THE DOOR:

5. Center punch holes "a" and "d" marked earlier.

6. Drill two (2) pilot holes "a". **Caution: Be sure to drill STRAIGHT through the door.**

7. Drill pilot hole "d". **Caution: Be sure to drill STRAIGHT through the door.**

8. At the outside and inside hole "d", drill a 3/4" hole.

HOLES "a"	HOLE "d"
INSIDE (Metal Doors Only)  5/16"	 3/4"
OUTSIDE  1/2"	

11. Drill holes "a" according to the chart above.

ASSEMBLING THE OUTSIDE TRIM AND BACKPLATE

12. Align the hex stand-offs and trim assembly through the drilled holes (see below).

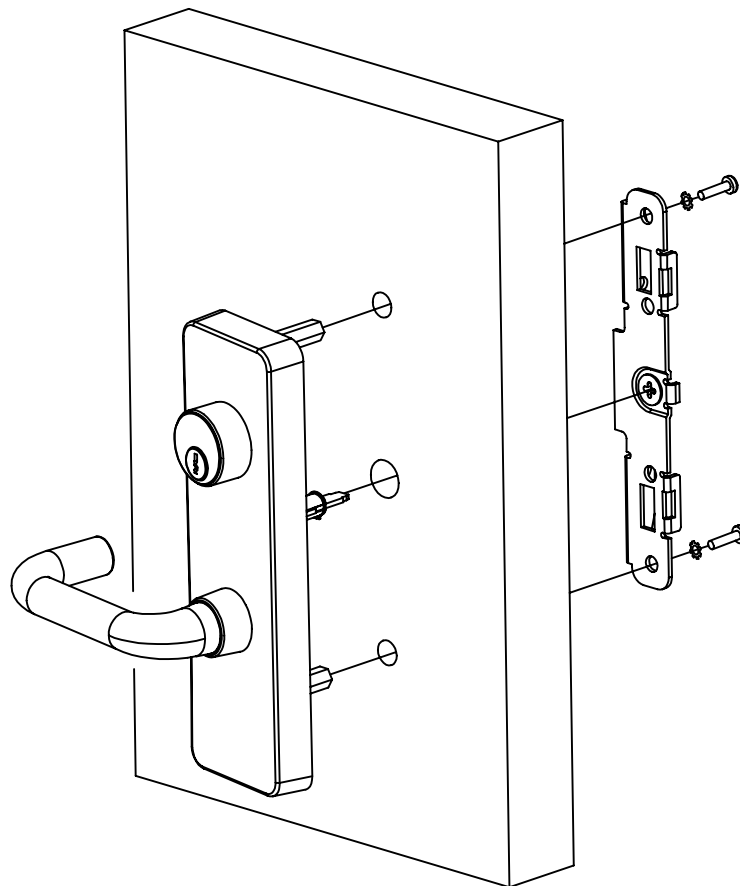

13. Align the tail piece extension into the backplate's trim cam on the inside face of the door.

14. Fasten the backplate to the inside face of the door with lockwashers and 1/4-20 machine screws provided with Exit Device Hardware Kit.

Caution: The lever should easily operate the inside trim cam.

15. Resume the panic hardware instruction.

CHANGE LEVER HANDING
(Refer to figure on next page)

- A. Remove tailpiece extension assembly screw. (Remove tailpiece extension assembly if necessary.)
- B. Remove lower stand-off and stop plate.
- C. **WARNING: Springs under pressure!** Remove spring retaining plate. Carefully remove the springs.
- D. Switch lock spring to opposite side (for 09 function only).
- E. Remove top gear.
- F. Loosen the clutch center screw approximately two (2) turns. Bend locking tab back to disengage with notch.
- G. Slide the locking bar away from the rack. Remove the rack while rotating the lever.
- H. Continue rotating the lever to the opposite side.
- I. Rotate the lever to the position shown. Partially engage the rack and the clutch gear on the opposite side.
- J. Rotate the lever until the rack is completely seated.
- K. Insert the top gear.
- L. Add permanent thread locking adhesive and tighten the clutch center screw. Bend tab over screw notch so that screw cannot turn.
- M. **Warning: Springs under pressure!** Install the springs. Hold the lever in the open position, firmly compressing the springs in place.
- N. While holding the lever in the open position, replace the spring retaining plate and fasten the two (2) screws.
- O. Reverse the stop plate and fasten the stand-off.
- P. Replace tailpiece extension assembly (if removed) and assembly screw. Handing is complete.

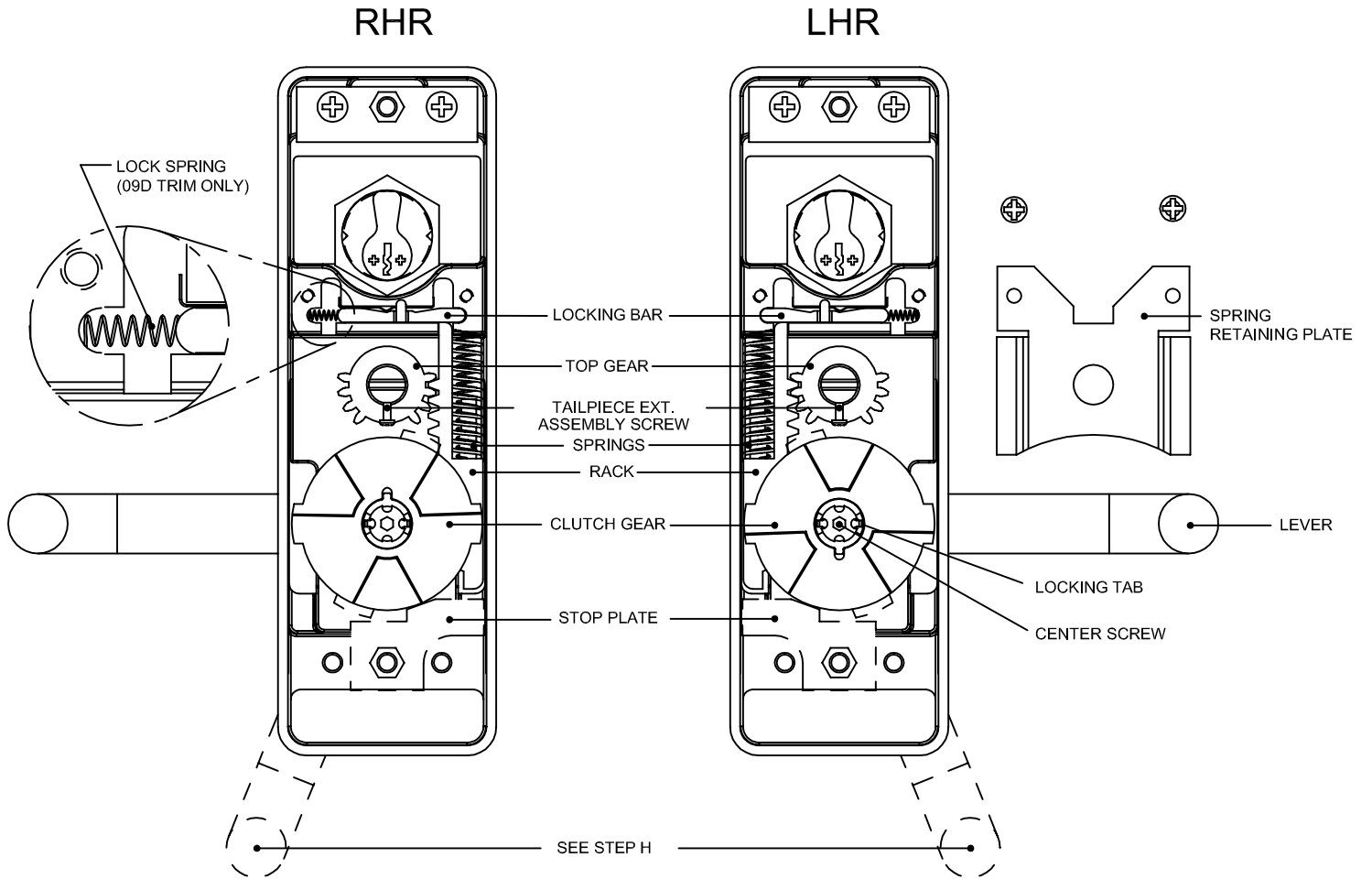

View from back side
 09D function only
 (with Spring Retaining Plate removed)