

TAILGATE DETECTION SYSTEM

INTRODUCTION

This manual is designed to guide the architect, integrator and installer through a step-by-step process that covers all aspects of planning, installing and operating the Tailgate Detection System.

The manual is divided into sections that cover Site Preparation, Installation and Operation including an Appendix that contains Specifications, Troubleshooting, Warranty and other helpful information.

There are several stages that the installation will encompass:

1. Pre-installation / Site Preparation
2. Physical Mounting
3. Wiring
4. Sensor Alignment and Adjustment
5. Mode Selection
6. Signal Processing Adjustment
7. Operation

Thank you for choosing products from Designed Security Inc. for your installation.

We are always looking for ways to better meet our customer's needs, and DSI welcomes any constructive feedback regarding how we may make this manual or our products better for you.

Please feel free to contact us by phone, e-mail, or USPS with your suggestions. Our contact information is at the bottom of this page.

SITE PREPARATION *(a guide for the architect, planner and integrator)*

Maximum Doorway Width

The ES520 is not designed to span a doorway greater than 80" in width. DSI does not make any claim that the ES520-RRS will perform to normal standards if this distance is exceeded.

Electromagnetic Interference (EMI)

Keep ES520 cabling separate from cables used for high current devices, such as Mag Locks and Door Strikes. Long parallel runs with such cables can induce unwanted "noise" on adjacent wiring.

Spacer Kit (*optional*)

If the application requires mounting the ES520 to the outside of a door molding or door trim the Spacer Kit may be required in order for the IR beams to have a clear, unbroken light path. Contact DSI regarding the spacer kit if it is required to complete your installation.

Wiring Considerations

Plan which Inputs and Outputs you will need for your installation and where the wiring is going to be run. Take into consideration whether you will be:

- a) Using the A.D.A. Entry and Exit Inputs,
- b) Configuring for Card In/Card Out or Card In/Free Exit and,
- c) Monitoring any of the Outputs remotely.

Determine the gauge of wire needed for the Power wires by using the "Power Wire-Run Gauge Calculator" (found in the Appendix) that shows how to calculate, step-by-step, the required gauge of wires based upon wire length from Power Supply and Amps required for system operation. Provide an Electrical Ground to the unit for the ESD Ground wire attachment

Light Path

Take into consideration door knobs or any other potential obstructions to the Infrared Beam's light path when planning the mounting location.

INSTALLATION

Physical Mounting of the TDS Enclosure units

Mounting Detail

Remove the covers from the TDS units by using the hex-key (provided) to remove the screw at bottom of cover.

The TDS is always mounted on the side of the doorway opposite of the door swing.

NOTE: The TDS will not operate on double swinging doors.

When facing the TDS mounting-side of the doorway, the Reflector unit is always mounted on the right side of the door. The Control unit (with the key-switch) is always mounted on the left side of the door.

Use each unit as a template to mark, and then pre-drill, mounting and wire access holes. Make each unit level and plumb prior to marking. This will help assure proper optical alignment.

Pull all cables through the wire access hole in the base units taking care not to strip insulation on sharp edges of any cutouts.

Mount the units to the door frame or wall using appropriate fasteners for the surface. The units should be mounted securely to prevent any vibration and movement resulting from door operation.

If the door frame is not a grounded surface, the units should be electrically connected to building ground using the provided ground strap. Lack of proper grounding of the units can result in non-warranty Electro-Static Discharge damage to the TDS.

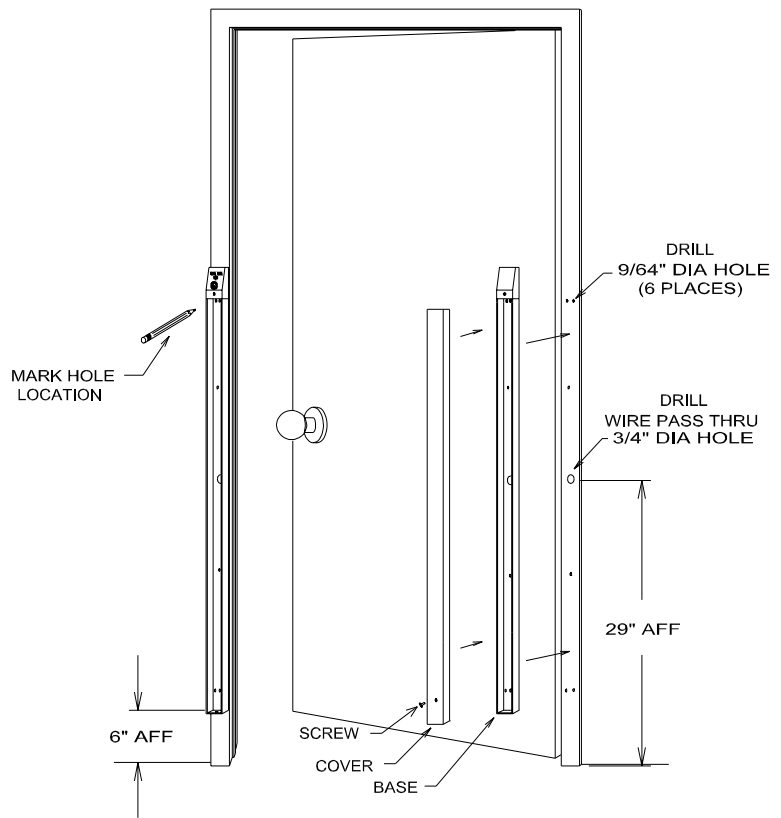

ES520-RRS TAILGATE DETECTION SYSTEM

WIRING CONNECTIONS

Attach the following wires to the appropriate Inputs and Outputs from the Power Supply, Access System and to the Monitoring System as required for your installation. Some Input and Output wires may not need to be used, depending upon the installation requirements.

SYSTEM INPUTS [TP2]:

Power -

1 Red (+) and 1 Black (-)(22 AWG min. shielded)

Connect power from a 12VAC, or 12VDC, or 24VDC-*only* @ 250 mA (minimum) power supply to the red and black power wires. **NOTE: J1 IN=12 volt, OUT=24 volt.** [Use form in Appendix to determine wire gauge requirement]

Door Contact -

Green pair (22 AWG min. shielded)

Door Contact recommended if a door is present. If no door contact is used, then leave these wires "open." The door contact input is not required, but the ES520 operates in a higher security mode without it. When the TDS is used with a door, and without a contact input, the simple action of reaching for the door may cause frequent false alarms.

Remote Reset/Bypass -

Yellow pair (22 AWG min. Shielded)

Connect to remote N/O switch to have reset/bypass operation. If not used, leave wires "open"

Valid "Exit Card" -

Gray pair (22 AWG min. Shielded)

Connect to N/O dry contact "Valid Exit" output from Access Control System. Short these wires to enable "Free Exit" operation.

Valid "Entry Card" -

White pair (22 AWG min. Shielded)

Connect to N/O dry contact "Valid Entry" output from Access Control System. This input, or an ADA input, is required in order for the unit to function.

NOTE: The Access System's Valid Entry and Exit inputs to the TDS should be a momentary closure of less than 1 second (.5 seconds is recommended) to allow proper operation with multiple reads/users during peak traffic periods.

ADA Valid "Exit Card" -

Pink pair (22 AWG min. Shielded)

This input is for Americans with Disabilities Act requirements for access. If your installation must be ADA compliant, then connect your N/O ADA valid Exit output from your Access Control System to this pair of wires. (not the same as described in #4) If not used, leave wires "open". In an ADA Entry, Free Exit environment, ADA Cards must still be presented for Exit. Otherwise, ADA users may cause false alarms on exit.

ADA Valid "Entry Card" -

Violet pair (22 AWG min. Shielded)

This input is for Americans with Disabilities Act requirements for access. If your installation must be ADA compliant, then connect your N/O ADA valid Entry output from your Access Control System to this pair of wires. (not the same as described in #5) If not used, leave wires "open".

ES520-RRS TAILGATE DETECTION SYSTEM

RELAY OUTPUTS [TP5]:

JUMPERS - All outputs are jumper selectable as N/O or N/C dry contacts. See nomenclature on the Control Board near each of the four Output jumpers for selection information.

Alarm Status -

Pink w/Stripe pair (22 AWG min.)

Dry contact, relay output that may be connected to remote monitoring equipment.

Bypass Status -

Violet w/Stripe pair (22 AWG min.)

Dry contact, relay output that may be connected to remote monitoring equipment.

Door Status -

White w/Stripe pair (22 AWG min.)

Dry contact, relay output that may be connected to remote monitoring equipment. If no door contact is used, this output will not change state.

Valid Passage -

Brown w/Stripe pair (22 AWG min.)

Dry contact, relay output that may be connected to remote monitoring equipment.

REMOTE ANNUNCIATOR OUTPUT [TP4]: (Included in R1 & R2 option kits)

Connect all wires to same-colored wires on the optional Remote Annunciator.

ESD GROUND:

Connect the ESD Ground wires to a known building/earth ground.

Once the necessary Wiring Connections are made, based upon the requirements of your particular installation, you are ready to continue to the next step, Sensor Alignment and Adjustment.

SENSOR ALIGNMENT AND ADJUSTMENT

The Sensors are aligned and tested prior to shipping. If the units have been positioned with care, the IR optical sensors likely will require no further physical adjustment.

Once the two assemblies are in proper physical alignment, and the wiring is completed, check the Sensor Alignment as follows;

- Switch on power to the unit[s] to be checked.
- Alignment is indicated by the LED's on the end of each sensor.

Red and Green ON simultaneously indicate that the Sensor is in alignment with the Reflector and in a stable operating state. (Lock indication)

- Block the Sensor and associated half of Reflector which is not being checked, using masking tape, or by covering with a card, See illustration.

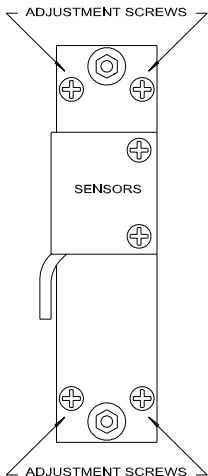
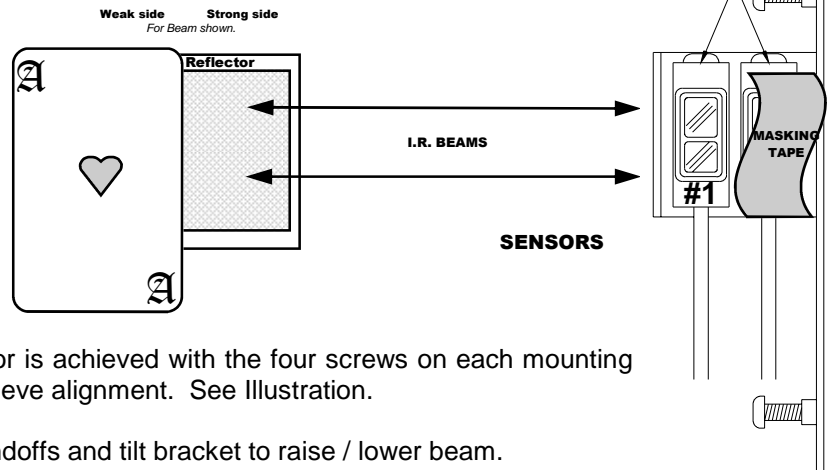
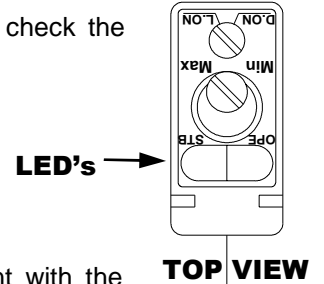

- Adjustment of the Sensor is achieved with the four screws on each mounting bracket as necessary to achieve alignment. See Illustration.

Loosen Mounting Standoffs and tilt bracket to raise / lower beam.

Turn Adjustment Screws to move beam right / left.

If may be necessary to loosen Mounting Standoffs to adjust screws.

- Observe the Sensor LED's for "Lock" indication. (Both LED's on)
- If necessary, paired beams may be adjusted separately by lightly bending the bracket Sensor #1 (shown above) is mounted on, after adjusting the other Sensor (shown masked above) for "Lock" indication.

The Gain adjustment on each Sensor is pre-set at during assembly of the product. Gain should not be adjusted in the field.

ES520-RRS TAILGATE DETECTION SYSTEM

MODE SELECTION

Entry / Exit Direction Select

A Direction Mode select jumper [J2] is located on the Control Board. The programming jumper defines which direction is considered Entry and which direction is Exit for each installation.

The Mode Selection Jumper diagram below shows how J2 affects the direction for both Free Exit and Card Out applications.

The ES520-RRS is shipped with the J2 Jumper installed. (Default)

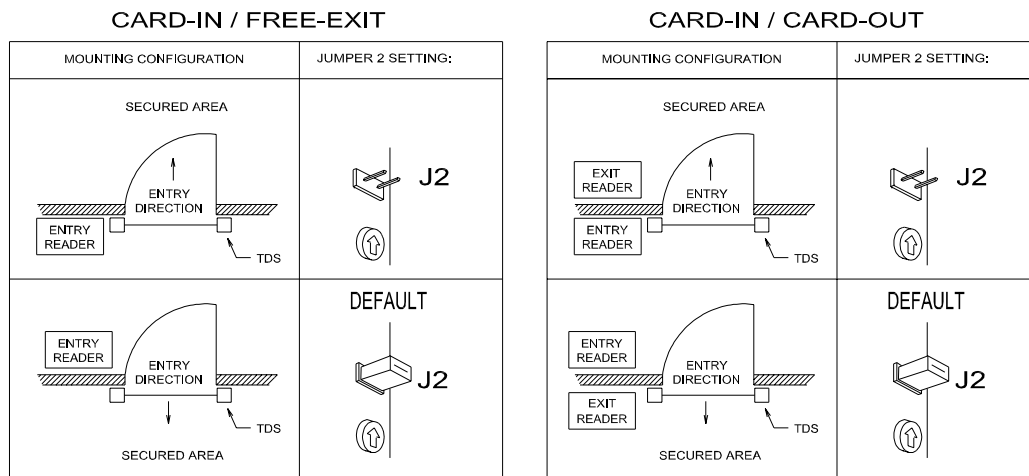

Mode Selection Jumper Diagram

Free Exit / Card Out Select

The TDS has two different operational modes "Card-in / Free-Exit" and "Card-in / Card-out". The TDS comes pre-configured from the factory to operate in the "Card-in / Card-Out mode."

NOTE: To return to the Card-in/Free-Exit mode easily, "short" the wire loop on the Valid Exit Card input for ten seconds. The mode will remain in "Free Exit" as long as the Valid Exit Card input remains shorted.

TIP: If the installation requires changing from "Card Out" to "Free Exit" at different times during the day, then you may have your access system provide a "short" to the Valid Exit Card input during the hours when Free Exit is desired. A Timer Relay may also be used to accomplish this.

SIGNAL PROCESSING ADJUSTMENT

The signal processing board has four adjustment pots which effect the time delays associated with direction sensing and tailgate operation. These times are preset at the factory and should not need adjustment.

However, if the TDS operation needs to be tailored to a specific installation, these pots can be adjusted. The four adjustments are:

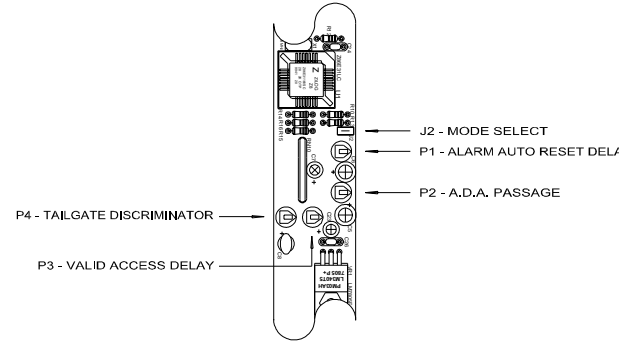

Tailgate Discriminator

Adjustable from 0 (CW) to .5 (CCW) seconds. This delay adjusts the sensitivity of the processing. It should be as short as possible to prevent possible tailgate violations. However, if false alarms are occurring because of umbrellas, purses, or long-legged people, then this delay will need to be lengthened. Factory pre-set at .25 seconds.

Valid Access Delay

Adjustable from 0 (CW) to 10 (CCW) seconds. This delay adjusts the amount of time that the TDS remains shunted after receiving a valid card. The TDS re-arms at the end of this delay if no passage has occurred. Factory pre-set at 5 seconds.

ADA Passage

Adjustable from 0 (CW) to 20 (CCW) seconds. This delay adjusts the amount of time that the TDS remains shunted after an ADA user begins passage. A wheelchair passing through the sensing area will cause an alarm if the normal valid card input is used. In accordance with the ADA 1990, cards issued to handicapped persons should activate the Handicapped valid card input, this allows a wheelchair bound person to use a TDS controlled door without generating false alarms. This delay should be set long enough to allow a wheelchair to pass through without leaving the door unsecured after passage. Factory pre-set at 10 seconds.

Alarm Auto Reset Delay

Adjustable from 0 (CW) to 30 (CCW) seconds. This adjusts the amount of time that the Tailgate unit is in alarm before automatically re-setting. Factory pre-set at 15 seconds.

NOTE: Each of these adjustments decrease when turned clockwise and increase when turned counter-clockwise.

OPERATION

This section goes into more detail regarding the individual components, connections and operation of the TDS, as well as providing User Instructions that may be duplicated and distributed to the new users of the system.

System Overview

The **ES 520 Series Tailgate Detection System (TDS)** utilizes the building access control system to grant or deny access to the secured area. This system will insure that only one pedestrian enters a secured passageway for each valid card presented.

The TDS senses and processes pedestrian direction and head count data using the sensor arrays on a per-cycle basis. The system is designed to allow for *multiple valid card reads* (valid card count) without the need for each valid user to wait for the doorway to re-secure.

Components

The Tailgate Detection System (TDS) consists of two separate components, the Reflector unit and the Control unit. These modules are mounted in two (2) million mount enclosures so that the active modulated infrared sensing arrays are mounted on either side of a doorway or passageway. These components are used to monitor the entrance, sense pedestrian direction and count the people passing through the passageway.

Mode Selection

This system can be configured for *Card-in / Free-exit* or *Card-in / Card-out* operation (see "Mode Selection" in this document). One (1) person can pass through the TDS in the authorized direction for each valid card presented. Passing through the doorway in a secured direction without first presenting a valid card will result in an alarm, as will trying to pass multiple persons on one valid card. The Valid Passage output, when using Card In / Card Out mode, may be interfaced to a time and attendance system.

Card Reader Interface

Four separate inputs from a card reader are available to allow user access/egress. "Entry Card" and "Exit Card" are for normal access. They allow one person to walk through the doorway for each card presented. The ADA Valid "Entry Card" and ADA Valid "Exit Card" signals allow persons with wheelchairs and other mobility assisting devices to pass through the secured doorway without generating false alarms.

CAUTION: - ADA users can conceivably pass multiple persons on their card due to the nature of this type of access.

LOCAL CONTROL

Receiver/Control Unit

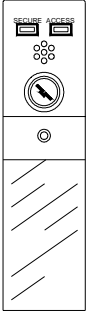

The Receiver/Control unit monitors the IR sensors and processes inputs from the access control system to determine and annunciate the status of a controlled doorway.

All system interface connections are made to the wire leads from the Control board.

The Control unit has a Control Panel that includes a Red LED, a Green LED, a Buzzer and a Bypass Key-switch to locally control and annunciate the operational status of the TDS.

The local key-switch will allow for Bypass of the TDS (remote indication of the Bypass status is an available output.) The system may also be Bypassed from a remote location (available input).

Mounting

The TDS **must** be mounted on the side of the doorway *Opposite of the Door Swing*. Designation of the "secured side" of the door depends on the actual installation. A programming jumper is provided to define the direction of travel for entry and exit traffic.

NOTE: The TDS will not operate on doors that swing in both directions.

REMOTE INDICATOR PLATE

Remote Annunciator

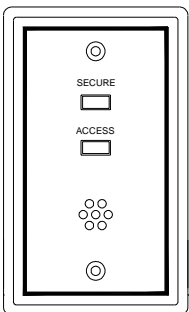

The Remote Indicator Plate (R1-Option shown at left) is mounted on the same side of the door as the Door Swing. (R2 Option is Mullion-mount version)

The Remote Indicator Plate has a Red LED, a Green LED, and a Buzzer to indicate the status of the TDS for users on the opposite side of the secured door from the TDS. (refer to figure in this document). This is usually found in a Card In / Card Out application.

This unit is available in a mullion mount configuration or on a single gang plate.

USER INSTRUCTIONS

Orientation

There are several aspects of the TDS that need to be understood to ensure smooth operation by the security personnel and the users.

The Tailgate Detection System [TDS] provides a security threshold which allows only one passage per valid card read.

There is a Detection Area between the two halves of the TDS unit where the equipment senses the presence and direction of travel of the user. This area must be kept clear of persons and objects except during an Access Period following a Valid Card Read or during a "Free Exit" passage. The area where doorknobs are usually mounted is a safe zone.

Any intrusion into the Detection Area without access being granted will generate a local alarm and an output to remote monitoring equipment.

There are audible and visual annunciation devices provided to indicate the current status of the TDS. The Annunciator is found on the Left-Hand half of the TDS and on the optional Remote Annunciator Panel used for remote reader applications.

	INDICATION	CONDITION	ACTION
LED's:	Red	Armed	Do Not Proceed
	Flashing Red	In Use, Alarm/Tamper	Wait
	Green	Bypassed	Free Access
	Flashing Green	Valid User Access	Proceed
AUDIBLE:	Single Beep	Valid User Access	
	Continuous	Alarm/Tamper	
	Pulsing	Beam Block Warning (only with door switch)	

There is a Key-Switch which may be used to Bypass or Reset the TDS.

The TDS is capable of holding multiple Valid Card Reads, so the following user does not have to wait for the person in front of them to complete passage before presenting their I.D. device.

Carrying and swinging of packages, purses, briefcases and other similar circumstances can appear to the TDS to be a person tailgating, so some education of the users is necessary to make them aware of this aspect of operation.

ES520-RRS TAILGATE DETECTION SYSTEM

Step by Step

When approaching the TDS, be careful not to intrude into the Detection Area **prior** to being granted access. Violating the Detection Area without access being granted will cause a nuisance alarm to sound if the door is not opened and will cause the Alarm Output to be enabled if the door is opened, and when there is no Door Input present.

- **Look** at the LED Display.

If the **Red LED is on**, then the system is armed and ready for use.

If the **Red LED is Flashing**, there is **another user** coming from the other direction or there is an **ADA user** in passage in either direction.

If the **Buzzer is sounding** while the Red LED is Flashing, the **unit is in Alarm**. **Wait**, do not enter the doorway.

- Present I.D. Device (Card, Badge, Biometric, etc.) as per the Access Control System manufacturer's instructions.
- When a **Valid I.D. has been accepted**, the TDS will **Beep** and the **Green LED will flash**. You may now **proceed** through the doorway. Keep loose items close to your person. Do not linger in the doorway, as this will cause a Beam Block Alarm.

The system will reset after a short period of time, if there is no passage detected. If this happens it will be necessary to re-validate the I.D. Device.

- When exiting through the doorway it may require an I.D. to be validated or it may be configured as a "Free Exit".
If an I.D. is required, use the same technique as in steps 1 - 3 above.

If Free Exit, then you may pass through the doorway without presenting an I.D.

NOTE: Be careful to proceed directly through the doorway, do not stop or return through the doorway without using the normal access steps outlined above, as this could cause an alarm to sound and Security personnel to be alerted.

NOTE: Be aware that swinging arms, briefcases, purses, packages, etc. may be seen as another person. Hold all such objects close to the body or the sides of the body when passing through the Detection Area to prevent unnecessary delays and alarms.

APPENDIX

ES520-RRS TAILGATE DETECTION SYSTEM

SPECIFICATIONS

Power:

12 VAC/VDC @ 250 mA
24 VDC [only] @ 250 mA

[Use chart in Appendix to calculate wire gauge needed]

Output Relays:

All Output Relay Contacts are rated at 500 mA @ 30 VDC

Each Output Relay's normal state is Jumper selectable. See Control Board diagram for more detail.

- | | | |
|----------------------|---|---|
| Alarm status | - | N/O or N/C relay output changes state during Alarm condition |
| Bypass status | - | N/O or N/C relay output changes state during Bypass condition |
| Door status | - | N/O or N/C relay output follows Door Input |
| Valid Passage | - | N/O or N/C relay output changes state momentarily after valid passage of a user through the TDS |

Dimensions:

- | | | |
|---------------------|---|------|
| Height | - | 48" |
| Width | - | 1.8" |
| Depth | - | 1.8" |
| Maximum Door Width- | | 80" |

Environmental:

- | | | |
|------------|---|------------|
| Temp Range | - | 0° - 50° C |
|------------|---|------------|

ES520-RRS TAILGATE DETECTION SYSTEM

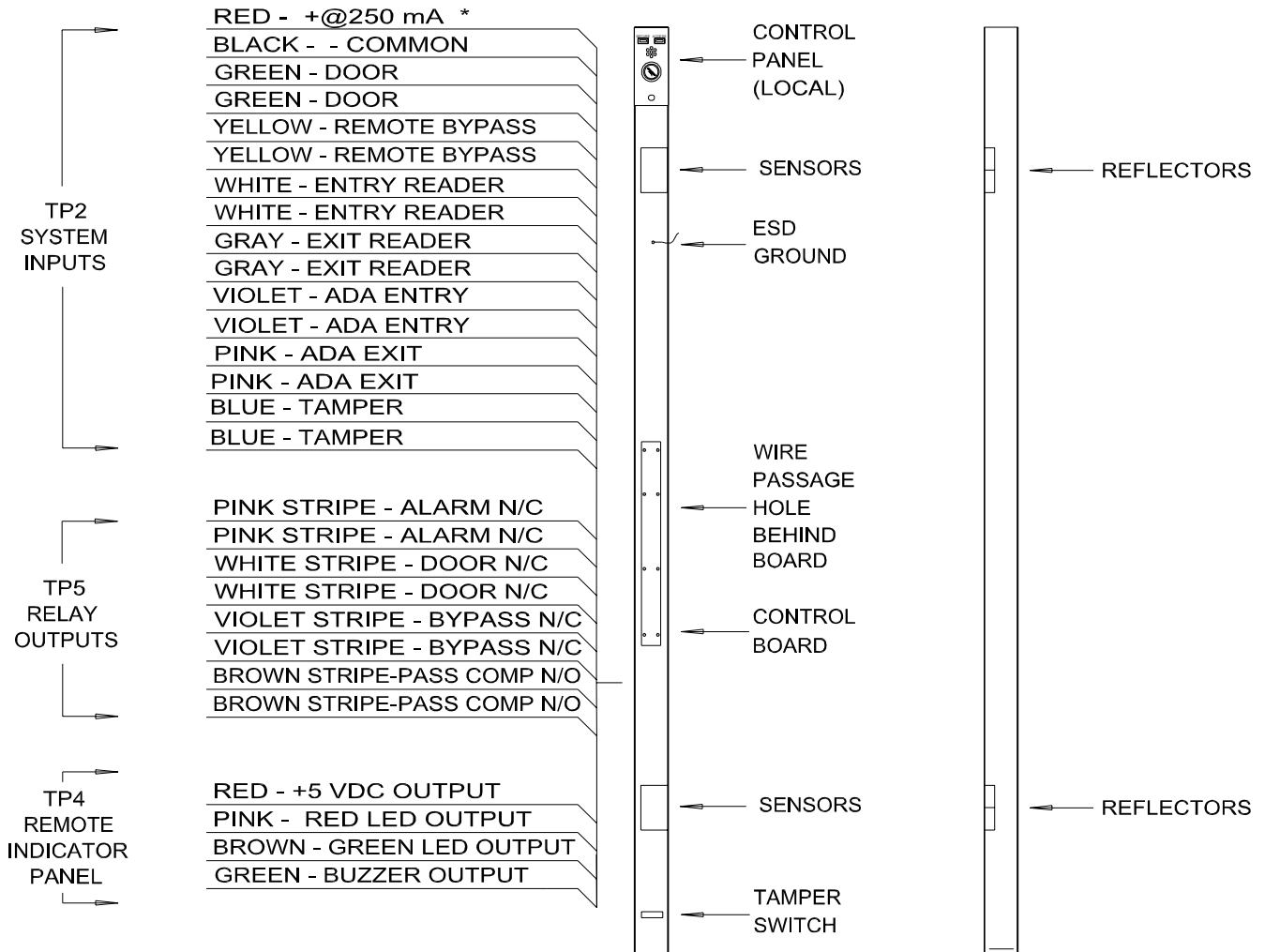

* SEE SPECIFICATIONS FOR POWER AND J1 INFORMATION

COMPONENT LOCATION AND INPUT / OUTPUT DETAIL

ES520-RRS TAILGATE DETECTION SYSTEM

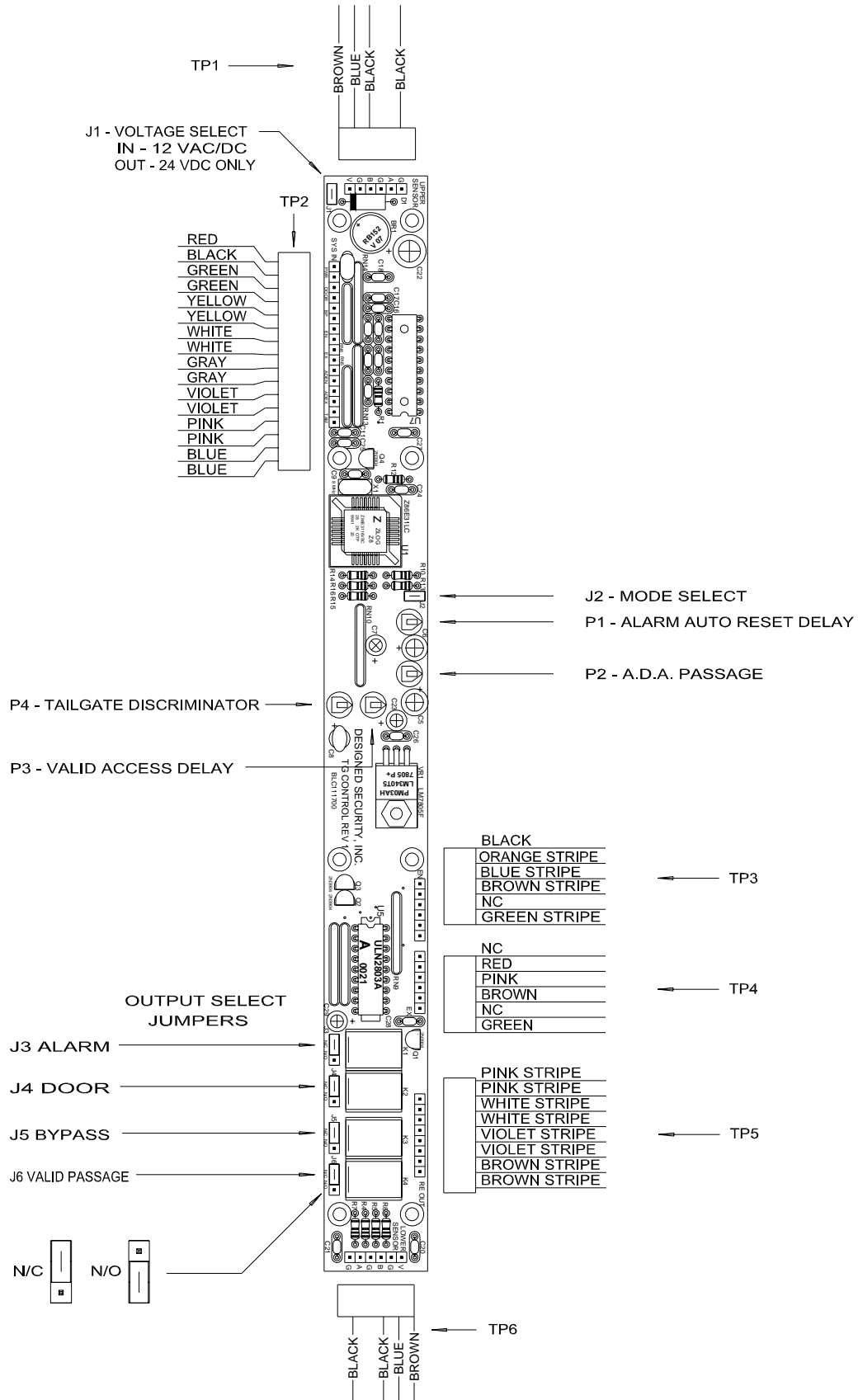

ES520-RRS TAILGATE DETECTION SYSTEM

DSI Power Wire-Run Gauge Calculator

Use this form to determine the wire gauge of the power trunk for equipment.

If used to calculate a:

- **“DAISY CHAIN”** application - one where all equipment is attached to the same trunk, you will need to calculate the total load and the total distance in wire run to the last load on the chain.
- **“HOME RUN”** application - where each piece of equipment is on a separate trunk returning to the central power supply, you use this form to determine the gauge for each run.
 1. Specify total Current load of all devices sharing this trunk, in Amps.
 2. Specify Distance of actual Wire Run (in feet) from power supply to most remote load.
 3. Multiply figures from line 1 and line 2
 4. Match final number to Table below to determine Wire Gauge needed to provide adequate Voltage.

TABLE

up to 45	22AWG
45 to 90	18AWG
90 to 170	16AWG
170 to 275	14AWG
275 to 415	12AWG
415 to 680	10AWG

If your result is greater than 680, make individual supply runs to each device, or sub-sets of devices, which are within the above parameters.

EXAMPLE: 3 devices @ .250, .500, .125 amps - total amps of .875

Distance of 150 ft.

150 times .875 = 131.25

131.25 falls into the category of 16 AWG wire.

USE THIS PAGE FOR FIELD NOTES

WARRANTY

The DSI product you have purchased is warranted to be free of defects in material and workmanship when properly installed, used and maintained according to instructions. DSI will, for a period of one (1) year from date of purchase, repair or replace any part which, upon our examination, proves to be defective under normal use.

DSI/DETEX SHALL NOT BE LIABLE FOR ANY DIRECT, INCIDENTAL OR CONSEQUENTIAL LOSS OR DAMAGE ARISING OUT OF THE FAILURE OF THIS DEVICE.

DS!