

Detex Corporation, 302 Detex Drive, New Braunfels, Texas 78130-3045
(830)629-2900 / 1-800-729-3839 / Fax (830)620-6711

E-MAIL: detex@detex.com INTERNET: www.detex.com

INSTALLATION INSTRUCTIONS FOR DETEX BE-961 BATTERY ELIMINATOR

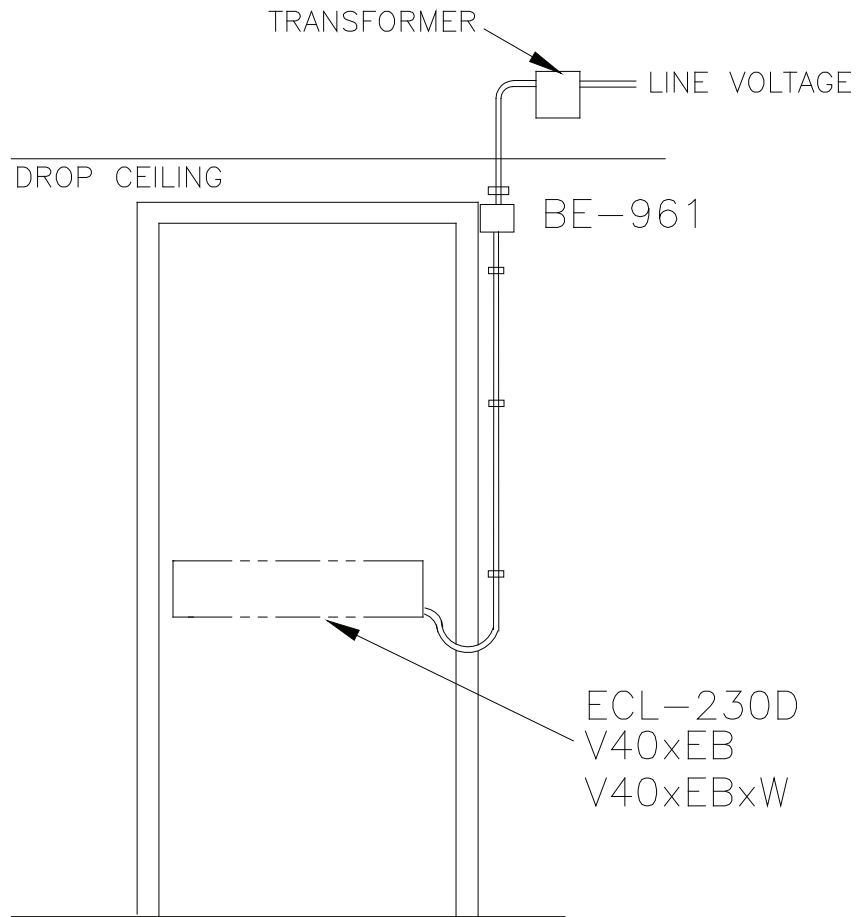

Owner's Copy

*** Note: Parts listed above will vary according to product configuration.**

BE-961-1 & BE-961-3 MODELS

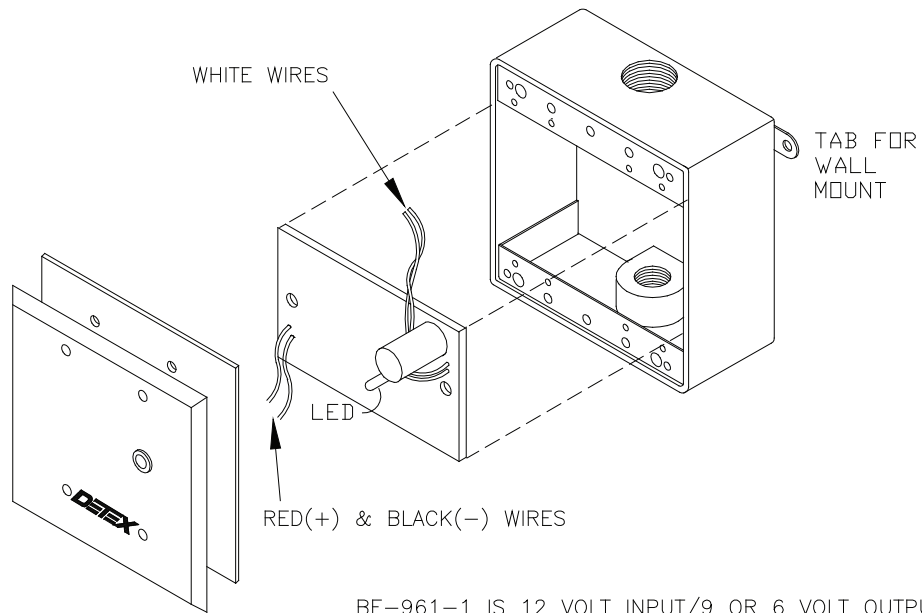

BE-961-1 IS 12 VOLT INPUT/9 OR 6 VOLT OUTPUT
(FOR 6 VOLT OUTPUT APPLICATIONS, CALL DETEX)

BE-961-3 IS 24 VOLT INPUT/9 VOLT OUTPUT.

BE-961-2 MODEL

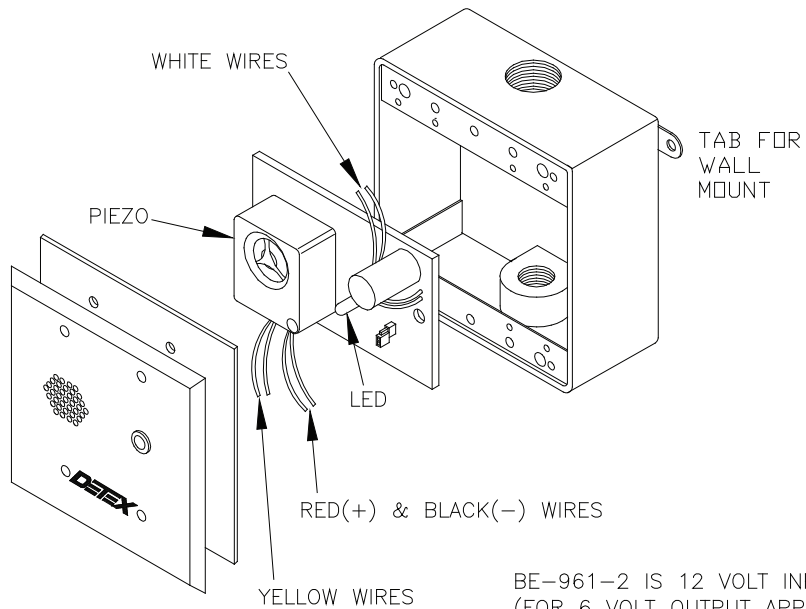

BE-961-2 IS 12 VOLT INPUT/9 OR 6 VOLT OUTPUT
(FOR 6 VOLT OUTPUT APPLICATIONS, CALL DETEX)

ECL-230D COVER MODIFICATION FOR USE WITH BATTERY ELIMINATOR

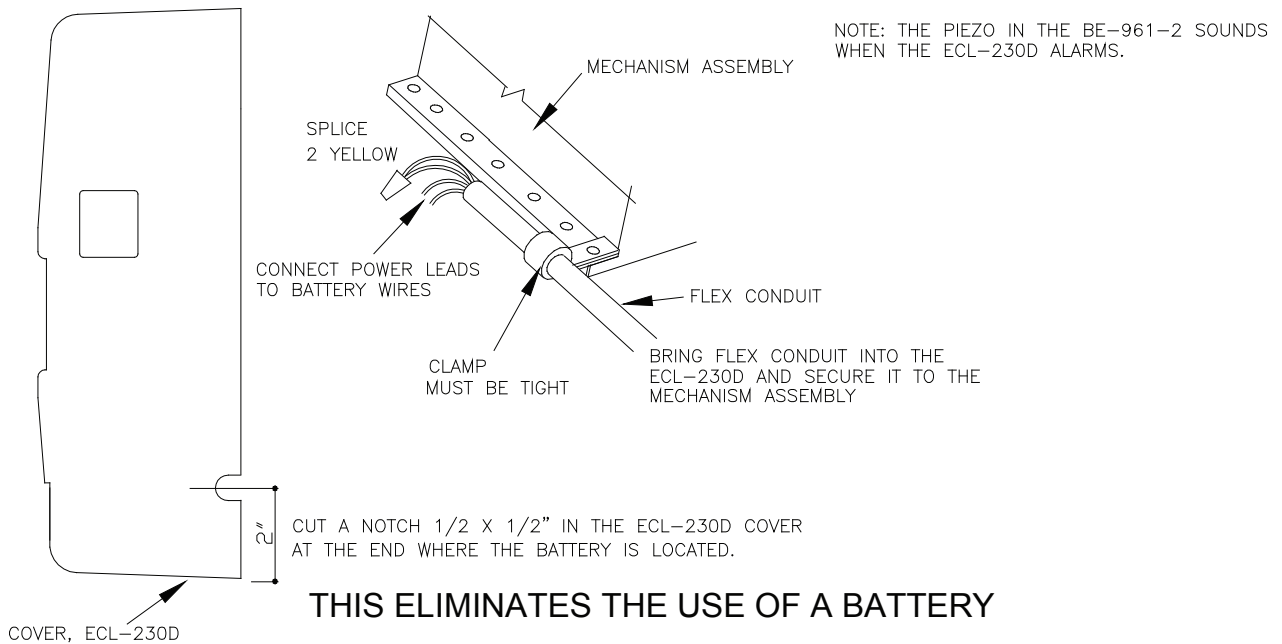

BE-961-1, -2, -3 WIRING CONNECTIONS

