

Detex Corporation, 302 Detex Drive, New Braunfels, Texas 78130-3045
(830)629-2900 / 1-800-729-3839 / Fax (830)620-6711
E-MAIL: detex@detex.com INTERNET: www.detex.com
**INSTALLATION INSTRUCTIONS FOR THE ECL-620
OUTSIDE LEVER TRIM FOR ECL-600**

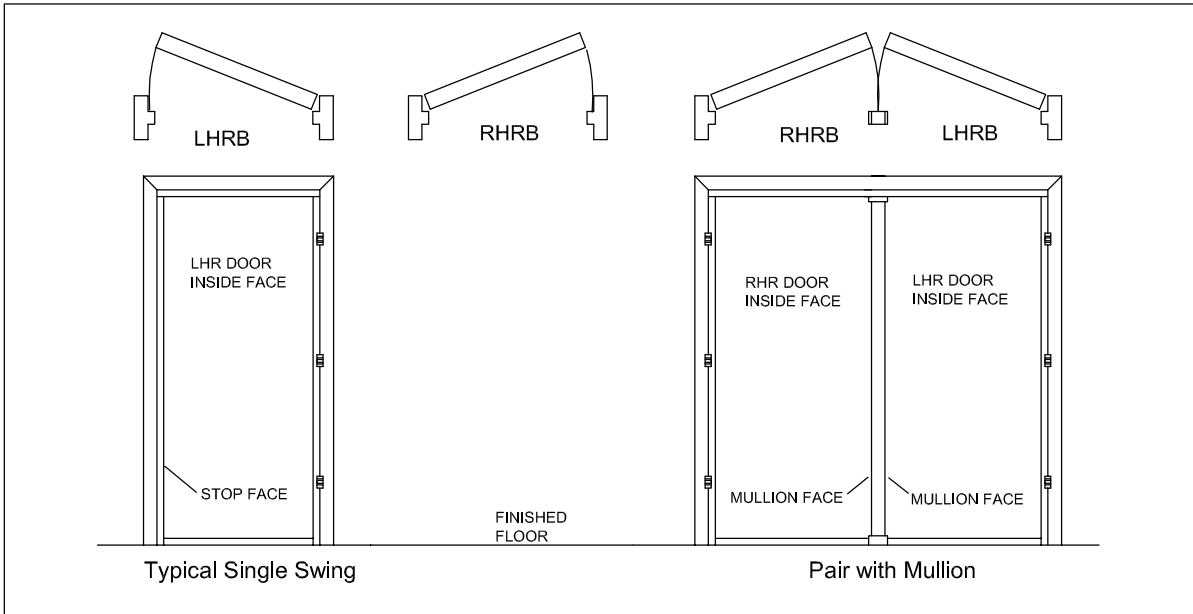
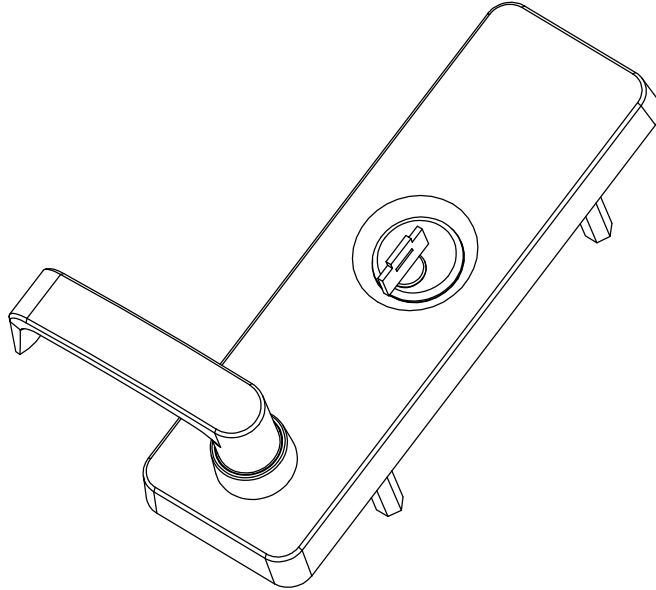

TOOLS AND SUPPLIES

- Pencil
- Adhesive Tape
- Center Punch
- Hammer
- Drill Motor
- Drill Bits & Taps - See Drill & Tap Schedule A (pg. 2)
- Screw Driver (Phillips Drive)
- Tape Measure

NOTICE: WHEN PRINTING TEMPLATES FROM THE WEB SITE, CHANGE PRINTER SETTINGS TO "PRINT TO FULL SIZE" (100%). **DO NOT SCALE TO FIT**

Drill & Tap Schedule A

Frame Holes	Wood Frame	Metal Frame	
A. (2 ea)	#14 Screws 3/16 Drill	#14 Screws #9 Drill	or 1/4-20 Machine screws #7 Drill; 1/4-20 Tap
B. (4 ea)	#10 Screws 1/8 Drill	#10 Screws #25 Drill	10-24 Machine screws #25 Drill; 10-24 Tap
Door INSIDE holes	Wood Door	Metal Door	
C. (6 ea) (holes 5,6,7,9,10,11)	#14 Screws 3/16 drill	#14 Screws #9 Drill	or 1/4-20 Machine screws #7 Drill; 1/4-20 Tap
D. (4 ea) (holes 1,2,3,4,)	#24, #25 or 9/64" drill bit (pilot thru hole) NOTE: Center of "E" holes CRITICAL TO DRILL STRAIGHT	SAME	
E. (4 ea) (holes 1,2,3,4)	1/2" wood bit HALFWAY thru door	1/2" drill bit HALFWAY thru door	or 1/2" hole saw HALFWAY thru door
F. (1 ea)	1/2" wood bit HALFWAY thru door	1/2" drill bit HALFWAY thru door	or 1/2" hole saw HALFWAY thru door
G. (1 ea)	1" wood bit THRU door	1" hole saw THRU door	
H. (2 ea) OPTIONAL FOR MULLION	#10 screws 1/8 drill	#10 screws #25 drill	or 10-24 machine screws #25 drill; 10-24 tap
Door OUTSIDE holes	Wood Door	Metal Door	
Locate the remaining "D" pilot holes on the outside face of door			
J. (1 ea)	1 1/2" wood bit at least 1 1/8" deep, but NOT THRU	1 1/2" hole saw at least 1 1/8" deep, but NOT THRU	

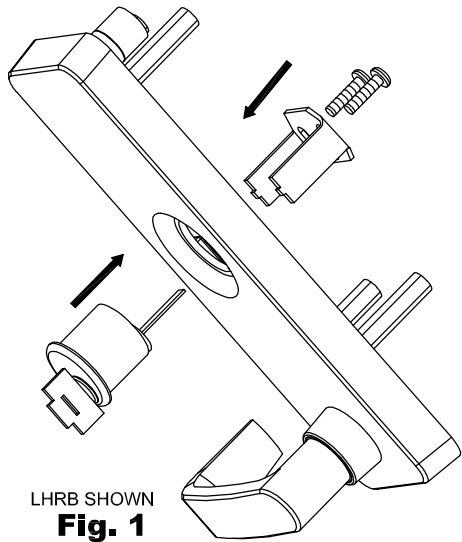

Preparing the ECL-620 for installation

1. Assemble the rim cylinder (not included) through the escutcheon and the cylinder retaining bracket as shown in Fig 1. Add cylinder spacer or cut the tailpiece as shown.

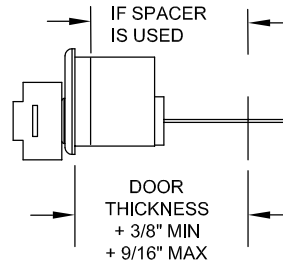

2. *See page 1 for handing illustrations*

The lever trim as received is handed for LHRB (Left Hand Reverse Bevel) doors. If your door is LHRB, proceed directly to step 3. If the door is a RHRB, then the lever needs to be reversed and the input extension needs to be moved from position A to position B.

(See Fig 2).

To do so:

- Remove the lever input extension from position A by first loosening its' setscrew. (See Fig 3)**
- Remove, likewise, the short locking collar at position B and discard it.**
- Remove screw and discard the retaining plate, screw and the loose parts under the retaining plate.**
- Remove lever from collar and rotate the lever 180°. Reinstall it through the butterfly cam. Secure the lever by tapping down the lever input extension taken from position A, onto the square shaft of the lever and tighten the set screw. When installed, the free end of the lever will point toward the hinged side of the door, not the strike.**

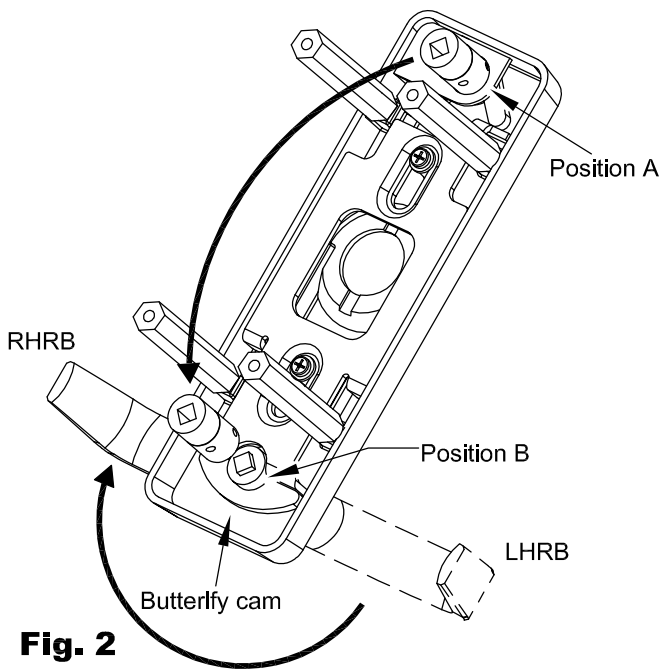

The outside lever trim is now completely assembled.

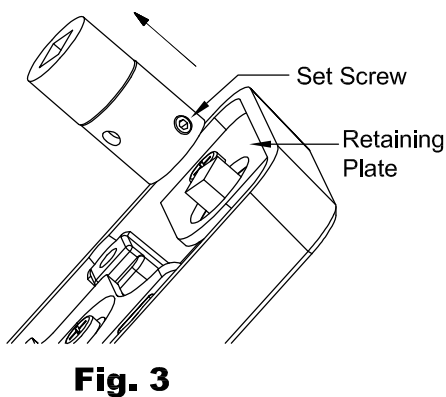

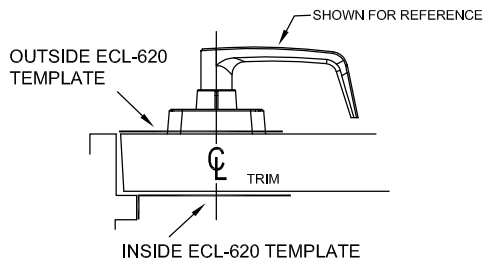

Fig. 4

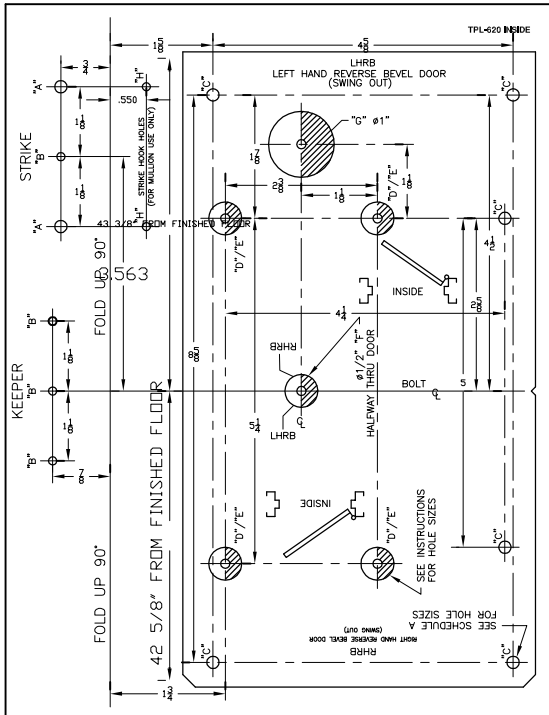
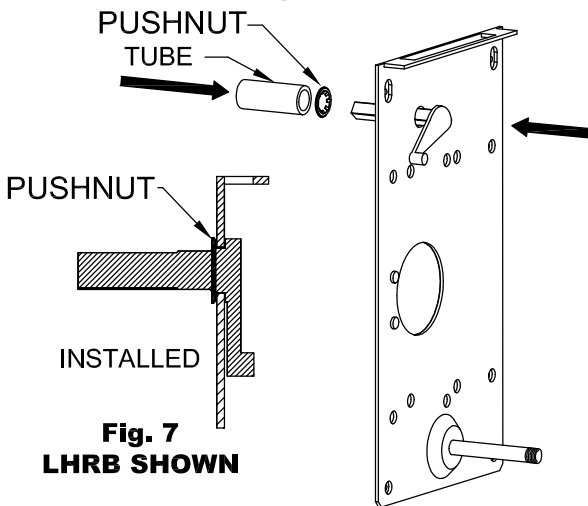

Fig. 5



**Fig. 7
LHRB SHOWN**

Preparing the Door & Frame

- 3. Orient the INSIDE template TPL-620 for proper door handing and tape to door per Fig 4. See Fig 5 for hole locations.**
- 4. Refer to Drill & Tap Schedule A (page 2):**
 - a. Mark, center punch and drill six (6) holes marked "C" on the door.**
 - b. Mark, center punch, drill and tap the two (2) outer holes of the strike, marked "A" on the frame.**
 - c. Mark, center punch, drill and tap the two (2)* outer holes of the keeper, marked "B" on the frame.**
- *DO NOT MARK OR DRILL CENTER HOLES MARKED "B" ON KEEPER AND STRIKE AT THIS TIME.**
- d. Mark and center punch then drill with pilot drill bit, the holes marked "D/E", "F" and "G".**

CRITICAL TO DRILL STRAIGHT AND LEVEL AS POSSIBLE. "E" HOLES LOCATE THE TRIM.

FIRE RATED pair of doors with mullion:

- e. Strike hook is required. Mark, center punch, drill and tap the two (2) holes marked "H" on the door.**
- 5. Drill 1/2" holes marked "E" and "F" halfway through door from inside to outside.**
- 6. Remove Inside Template TPL-620 from face of door and discard.**

PREPARING ECL-600 BACKPLATE FOR THE ECL-620 - Fig 7

- 7. Install the input lever cam onto the backplate with the push nut, using disposable tube as shown. Discard the tube after use.**

PREPARING THE OUTSIDE OF DOOR - Fig. 8

- 8. Place OUTSIDE template (TPL-620), align 4 holes marked "E" with pilot holes "D" and secure with tape.**
- 9. Ensure proper handing before proceeding.**
- 10. Drill 1" hole marked "G" through door.**
- 11. Mark, center punch and drill 1-1/2" hole marked "J" at least 1-1/8" deep from OUTSIDE to inside, but do not drill through.**
- 12. Locate 4 existing pilot holes marked "E" and drill Ø1/2" hole through door.**
- 13. Remove OUTSIDE template TPL-620 and discard.**

Fig. 8

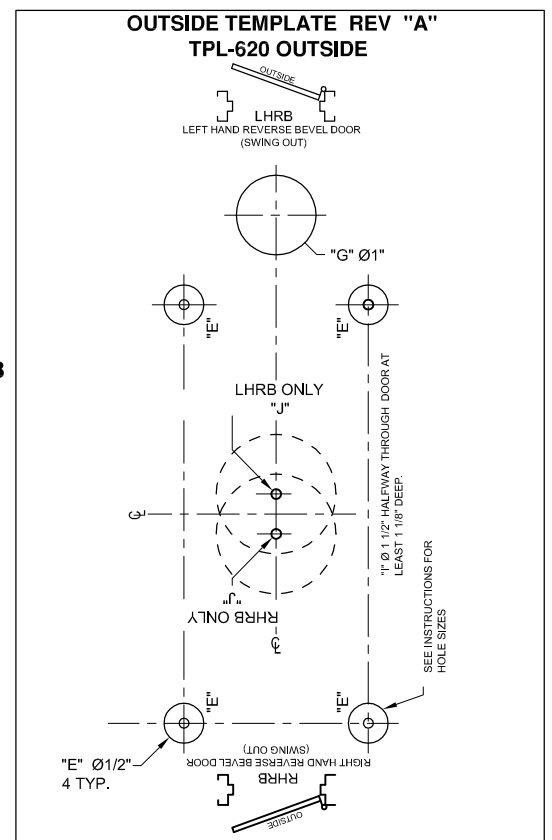

INSTALLATION

Fig. 9

14. Install backplate onto the door. Secure with two (2) screws at holes marked "5" and "7".
15. Align cam with hole marked "8" and tape to secure.
16. Insert ECL-620 LEVER TRIM into hole on door. Align key cylinder tailpiece through door. Align input extension with lever input cam.

TIP: Rotating trim lever back and forth and moving backplate facilitates alignment.

17. Install short 1/4-20 machine screw through hole marked "2".
18. Remove tape from cam and discard.
19. Install relatching assembly with two (2) #14 screws in holes marked "6" and "9".

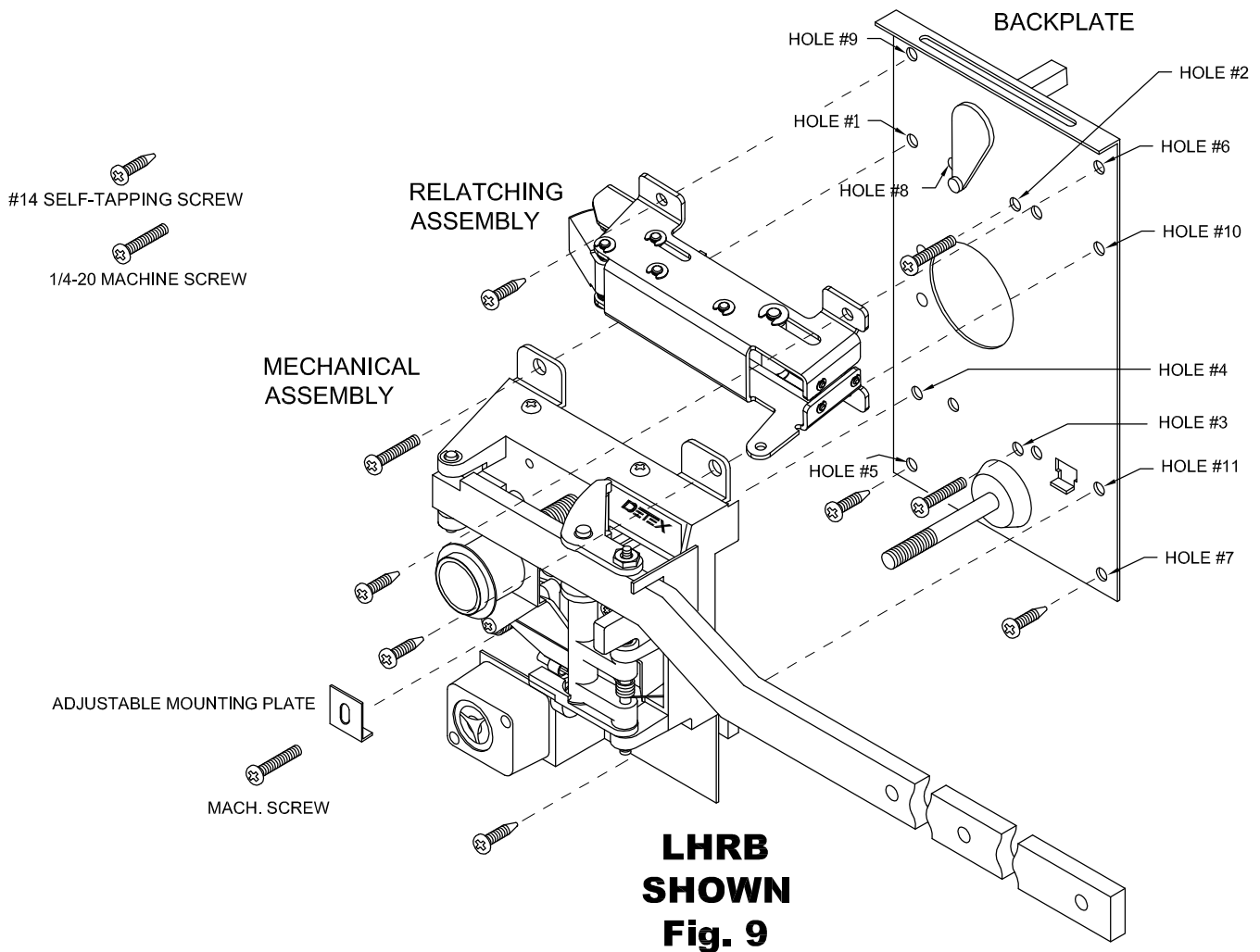

For further assistance contact Detex Technical Support at 1-800-729-3839

Fig. 10
20. Remove OKC retaining spring and align marks.

Fig. 10

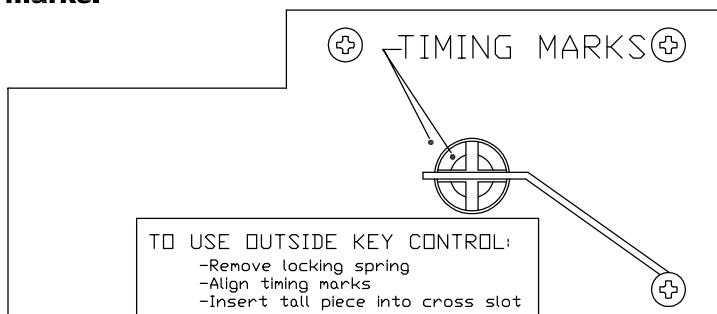

Fig. 11
21. Engage alignment bolt on mechanical assembly with alignment hole on relatching assembly as shown in Detail 1.
22. Install mechanical assembly with screws in holes marked "1, 10, 11 and 3".
23. Install adjustable mounting plate in hole marked "4".
24. Install actuating bar and lever.
25. Lubricate mechanism.
26. Engage bolt and latch into keeper and strike. Adjust keeper and strike as necessary. Tighten screws into place.
27. Drill center "B" holes for keeper and strike.
28. Install screws and tighten.

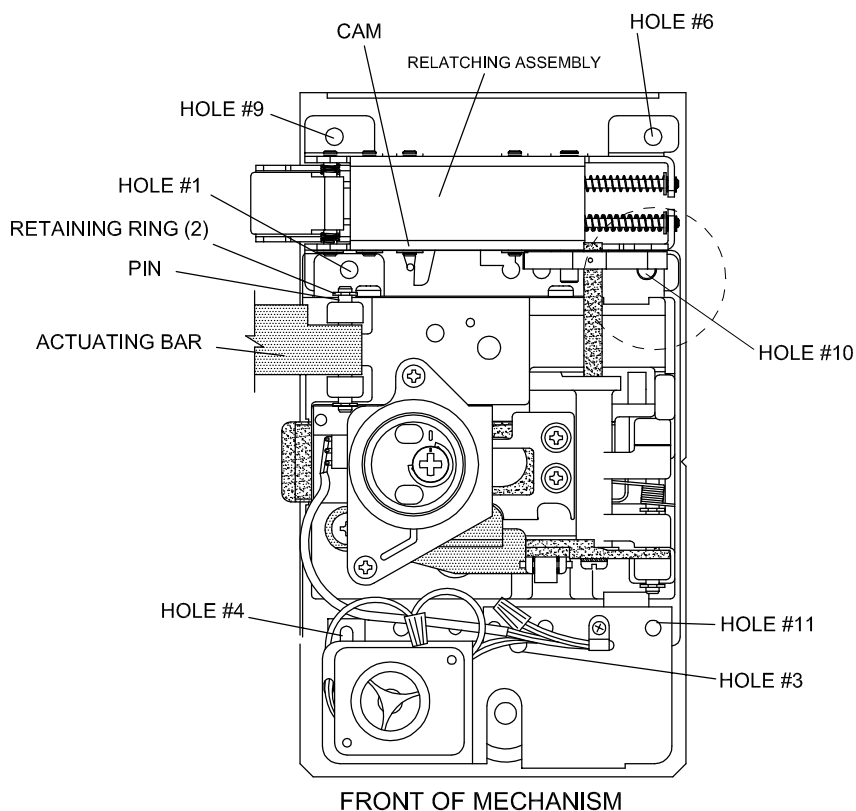
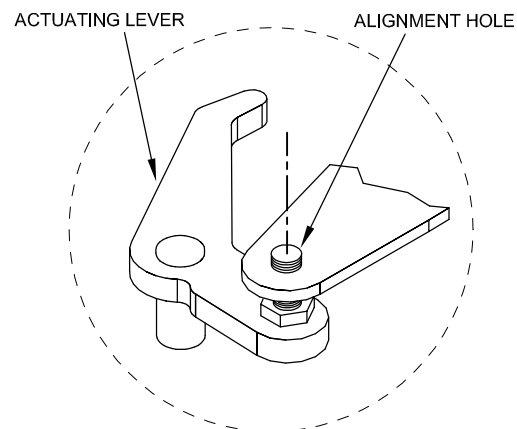

Fig. 11



DETAIL 1

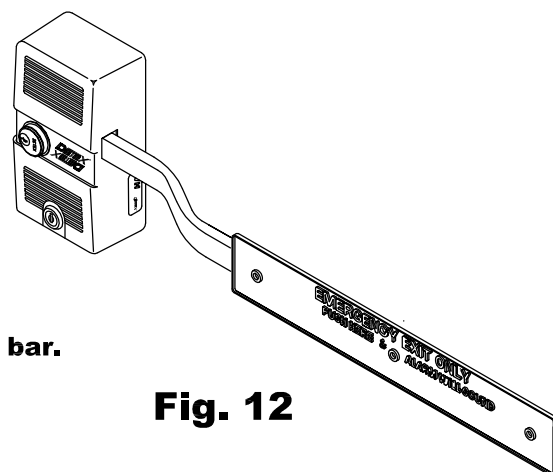
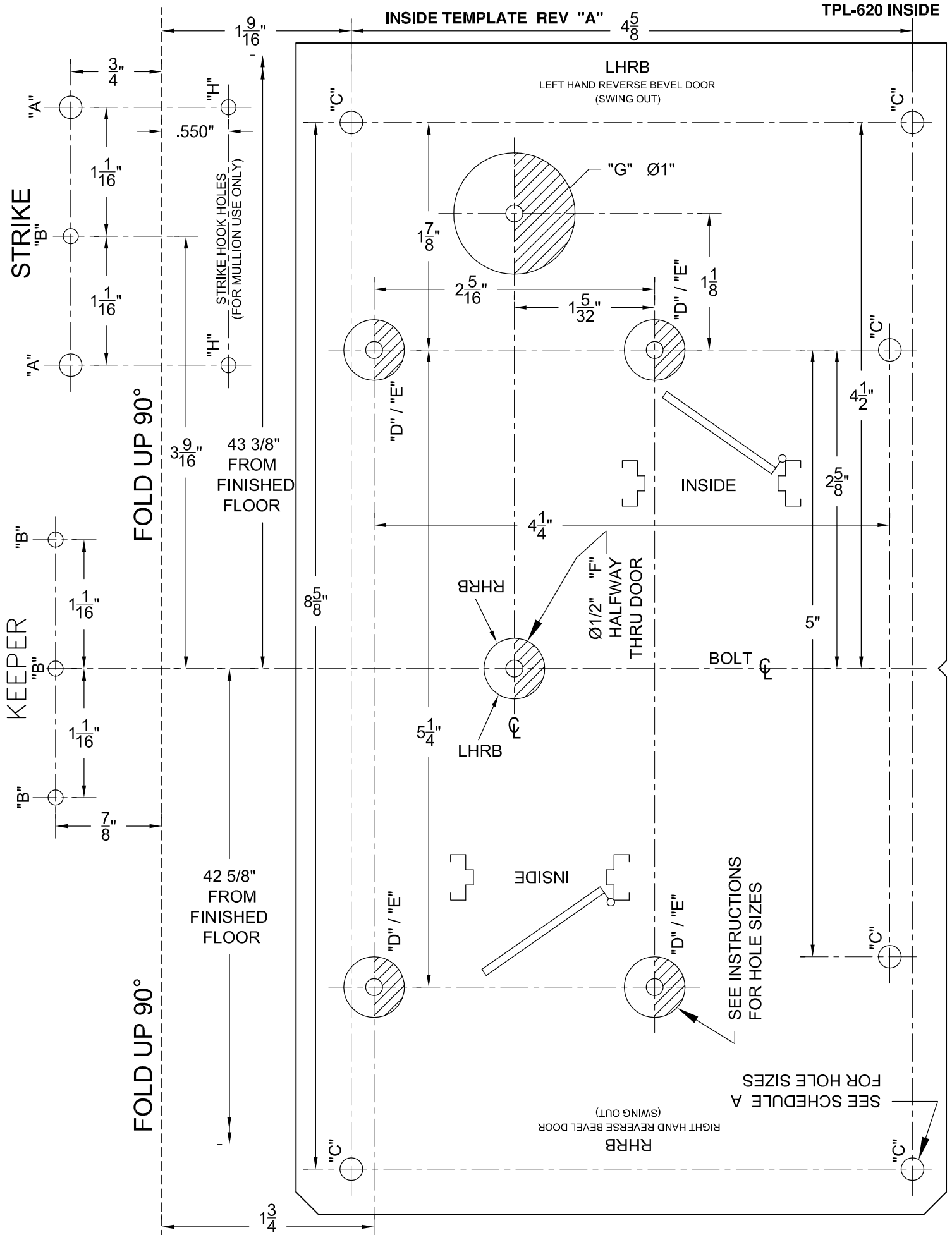

Fig. 12

Fig. 12
29. Install 9V battery.
30. Insert actuating bar through hole in cover and slide over bar.
31. Install paddle on bar and close and screw lock cover.

NOTE: DIMENSIONS MAY NOT BE ACCURATE WHEN PRINTING FROM WEBSITE. PLEASE CONFIRM DIMENSIONS WITH RULER BEFORE USE



NOTE: DIMENSIONS MAY NOT BE ACCURATE WHEN PRINTING FROM WEBSITE
PLEASE CONFIRM DIMENSIONS WITH RULER BEFORE USE

OUTSIDE TEMPLATE REV "A" TPL-620 OUTSIDE

